

# YAMAHA AV-85 PY

*4 Channel Amplifier Configuration*

*100W + 100W (8Ω) RMS Output Power, 0.1% THD, 20-20,000 Hz (Front)*

*15W + 15W (8Ω) RMS Output Power, 1% THD, 1,000 Hz (Rear)*

*2-mode Surround (Dolby pro logic/Natural)*

*7-band Graphic Equalizer*

*6 Audio Inputs, 2 Video Inputs*

*Adaptability for Both Conventional Speakers  
and YAMAHA Active Servo Processing Speakers*

*Remote Control Capability*

Thank you for selecting the YAMAHA stereo amplifier.

CENTER



## OWNER'S MANUAL

### CONTENTS

Safety Instructions .....	2
Caution .....	2
Warning .....	3
Supplied Accessories .....	3
YAMAHA Active Servo Technology .....	4
Connections .....	5
Surround-Sound Processor .....	7
Adjustment Before Operation .....	8
Operations .....	10
Remote-Control Transmitter .....	13
Notes about the Remote-Control Transmitter .....	14
Troubleshooting .....	14
Specifications .....	15

### IMPORTANT!

Please make a note of the serial number of this unit in the space indicated below.

Model:  
Serial No.:

The serial number is inscribed on the rear of the unit.  
Keep this Owner's Manual in a safe place for future reference.

### WARNING

To reduce the risk of fire or electric shock, do not expose this appliance to rain or moisture.



### • Explanation of Graphical Symbols



The lightning flash with arrowhead symbol, within an equilateral triangle, is intended to alert you to the presence of uninsulated "dangerous voltage" within the product's enclosure that may be of sufficient magnitude to constitute a risk of electric shock to persons.



The exclamation point within an equilateral triangle is intended to alert you to the presence of important operating and maintenance (servicing) instructions in the literature accompanying the appliance.

# SAFETY INSTRUCTIONS

---

- 1 Read Instructions – All the safety and operating instructions should be read before the appliance is operated.
- 2 Retain Instructions – The safety and operating instructions should be retained for future reference.
- 3 Heed Warnings – All warnings on the appliance and in the operating instructions should be adhered to.
- 4 Follow Instructions – All operating and other instructions should be followed.
- 5 Water and Moisture – The appliance should not be used near water – for example, near a bathtub, washbowl, kitchen sink, laundry tub, in a wet basement, or near a swimming pool, etc.
- 6 Carts and Stands – The appliance should be used only with a cart or stand that is recommended by the manufacturer.
- 6A An appliance and cart combination should be moved with care. Quick stops, excessive force, and uneven surfaces may cause the appliance and cart combination to overturn.
- 7 Wall or Ceiling Mounting – The appliance should be mounted to a wall or ceiling only as recommended by the manufacturer.
- 8 Ventilation – The appliance should be situated so that its location or position does not interfere with its proper ventilation. For example, the appliance should not be situated on a bed, sofa, rug, or similar surface, that may block the ventilation openings; or placed in a built-in installation, such as a bookcase or cabinet that may impede the flow of air through the ventilation openings.
- 9 Heat – The appliance should be situated away from heat sources such as radiators, stoves, or other appliances that produce heat.
- 10 Power Sources – The appliance should be connected to a power supply only of the type described in the operating instructions or as marked on the appliance.
- 11 Power-Cord Protection – Power-supply cords should be routed so that they are not likely to be walked on or pinched by items placed upon or against them, paying particular attention to cords at plugs, convenience receptacles, and the point where they exit from the appliance.
- 12 Cleaning – The appliance should be cleaned only as recommended by the manufacturer.
- 13 Nonuse Periods – The power cord of the appliance should be unplugged from the outlet when left unused for a long period of time.
- 14 Object and Liquid Entry – Care should be taken so that objects do not fall into and liquids are not spilled into the inside of the appliance.
- 15 Damage Requiring Service – The appliance should be serviced by qualified service personnel when:
  - A. The power-supply cord or the plug has been damaged; or
  - B. Objects have fallen, or liquid has been spilled into the appliance; or
  - C. The appliance has been exposed to rain; or
  - D. The appliance does not appear to operate normally or exhibits a marked change in performance; or
  - E. The appliance has been dropped, or the cabinet damaged.
- 16 Servicing – The user should not attempt to service the appliance beyond those means described in the operating instructions. All other servicing should be referred to qualified service personnel.
- 17 Power Lines – An outdoor antenna should be located away from power lines.
- 18 Grounding or Polarization – The precautions that should be taken so that the grounding or polarization is not defeated.



---

## CAUTION: READ THIS BEFORE OPERATING YOUR UNIT

---

- 1 To ensure the finest performance, please read this manual carefully. Keep it in a safe place for future reference.
- 2 Install your unit in a cool, dry, clean place – away from windows, heat sources, and too much vibration, dust, moisture or cold. Avoid sources of hum (transformers, motors). To prevent fire or electrical shock, do not expose to rain and water.
- 3 Do not operate the unit upside-down. It may overheat, possibly causing damage.
- 4 Never open the cabinet. If a foreign object drops into the set, contact your dealer.
- 5 Do not use force on switches, knobs or cords. When moving the set, first turn the unit off. Then gently disconnect the power plug and the cords connecting to other equipment. Never pull the cord itself.
- 6 Do not attempt to clean the unit with chemical solvents; this might damage the finish. Use a clean, dry cloth.
- 7 Always set the volume control to “-∞” before starting the audio source play; increase the volume gradually to an appropriate level after the play is started.
- 8 Be sure to read the “Troubleshooting” section on common operating errors before concluding that your unit is faulty.
- 9 Do not connect audio equipment to the AC outlets on the rear panel if that equipment requires more power than the outlets are rated to provide.

# WARNING: CHEMICAL CONTENT NOTICE!

The solder used in the manufacture of this product contains LEAD. In addition, the electrical/electronic and/or plastic (where applicable) components may also contain traces of chemicals found by the California Health and Welfare Agency (and possibly other entities) to cause cancer and/or birth defects or other reproductive harm.

## DO NOT REMOVE ANY ENCLOSURE COMPONENTS!

There are no user serviceable parts inside. All service should be performed by a service representative authorized by Yamaha to perform such service.

**IMPORTANT MESSAGE:** Yamaha strives to produce products that are both user safe and environmentally "friendly". We sincerely believe that our products meet these goals. However, in keeping with both the spirit and the letter of various statutes we have included the preceding messages and others in various locations in this manual.

## FCC INFORMATION (U.S.A.)

### 1. IMPORTANT NOTICE : DO NOT MODIFY THIS UNIT!

This product, when installed as indicated in the instructions contained in this manual, meets FCC requirements. Modifications not expressly approved by Yamaha may void your authority, granted by the FCC, to use the product.

**2. IMPORTANT :** When connecting this product to accessories and/or another product use only high quality shielded cables. Cable/s supplied with this product **MUST** be used. Follow all installation instructions. Failure to follow instructions could void your FCC authorization to use this product in the USA.

**3. NOTE :** This product has been tested and found to comply with the requirements listed in FCC Regulations, Part 15 for Class "B" digital devices. Compliance with these requirements provides a reasonable level of assurance that your use of this product in a residential environment will not result in harmful interference with other electronic devices. This equipment generates/uses radio frequencies and, if not installed and used according to the instructions found in the users manual, may cause interference harmful to the operation of other electronic devices.

Compliance with FCC regulations does not guarantee that interference will not occur in all installations. If this product is found to be the source of interference, which can be determined by turning the unit "OFF" and "ON", please try to eliminate the problem by using one of the following measures:

Relocate either this product or the device that is being affected by the interference.

Utilize power outlets that are on different branch (circuit breaker or fuse) circuits or install AC line filter/s.

In the case of radio or TV interference, relocate/reorient the antenna. If the antenna lead-in is 300 ohm ribbon lead, change the lead-in to co-axial type cable.

If these corrective measures do not produce satisfactory results, please contact the local retailer authorized to distribute this type of product. If you can not locate the appropriate retailer, please contact Yamaha Electronics Corp., U.S.A. 6722 Orangethorpe Ave, Buena Park, CA 90620.

The above statements apply **ONLY** to those products distributed by Yamaha Corporation of America or its subsidiaries.

## SUPPLIED ACCESSORIES

After unpacking, check that the following parts are contained.

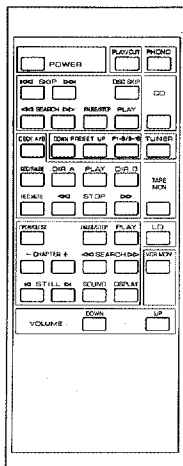

Remote Control Transmitter

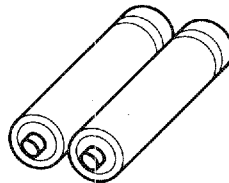

Batteries (size "AAA", R03)

# YAMAHA ACTIVE SERVO TECHNOLOGY

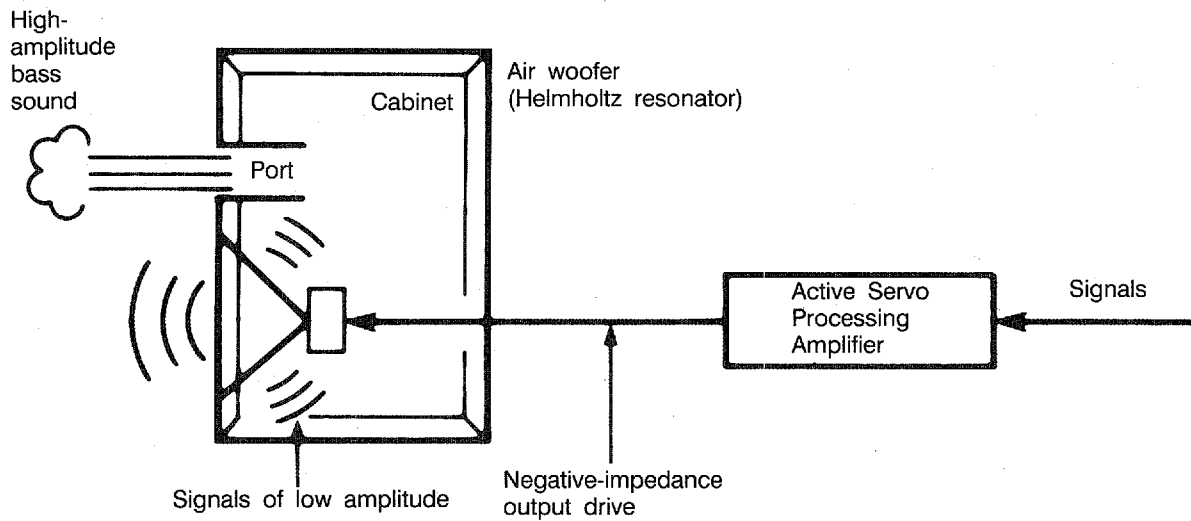

The theory of the Active Servo Technology is based upon two major factors, the Helmholtz resonator and negative-impedance drive. Active Servo Processing speakers reproduce the bass frequencies through an "air woofer", which is a small port or opening in the speaker's cabinet. This opening is used instead of, and performs the functions of, a woofer in a conventionally designed speaker system. Thus, signals of low amplitude within the cabinet can, according to the Helmholtz resonance theory, be output from this opening as waves of great amplitude if the design is such that the size of the opening and the volume of the cabinet are in the correct proportion to satisfy a certain ratio.

In order to accomplish this, moreover, the amplitudes within the cabinet must be both precise and of sufficient power because these amplitudes must overcome the "load" presented by the air that exists within the cabinet.

Thus it is this problem that is resolved through the employment of a design in which the amplifier functions to supply the signals. If the electrical resistance of the voice coil is reduced to zero, the movement of the speaker unit would become linear with respect to signal voltage, and, to accomplish this, a special negative-impedance output-drive amplifier for subtracting output impedance of the amplifier is used.

By employing negative-impedance drive circuits, the amplifier is able to generate precise, low-amplitude low-frequency waves with superior damping characteristics, and these waves are then radiated from the cabinet opening as high-amplitude signals. The system can, therefore, by employing the negative-impedance output drive amplifier and a speaker cabinet with the Helmholtz resonator, reproduce an extremely wide range of frequencies (28 Hz - 20 kHz) with amazing sound quality and less distortion.

The features described above, then, are combined to be the fundamental structure of the Active Servo Technology.

\* Refer to the page 6 for the detailed information on the adaptable speaker type.

# CONNECTIONS

Before attempting to make any connections to or from this unit, be sure to first switch OFF the power to this unit and to any other components to which connections are being made.

## AUDIO AND VIDEO CONNECTIONS

When making connections between this unit and other components, be sure all connections are made correctly, that is to say L (left) to L, R (right) to R, "+" to "+" and "-" to "-". Also, refer to the owner's manual for each component to be connected to this unit.

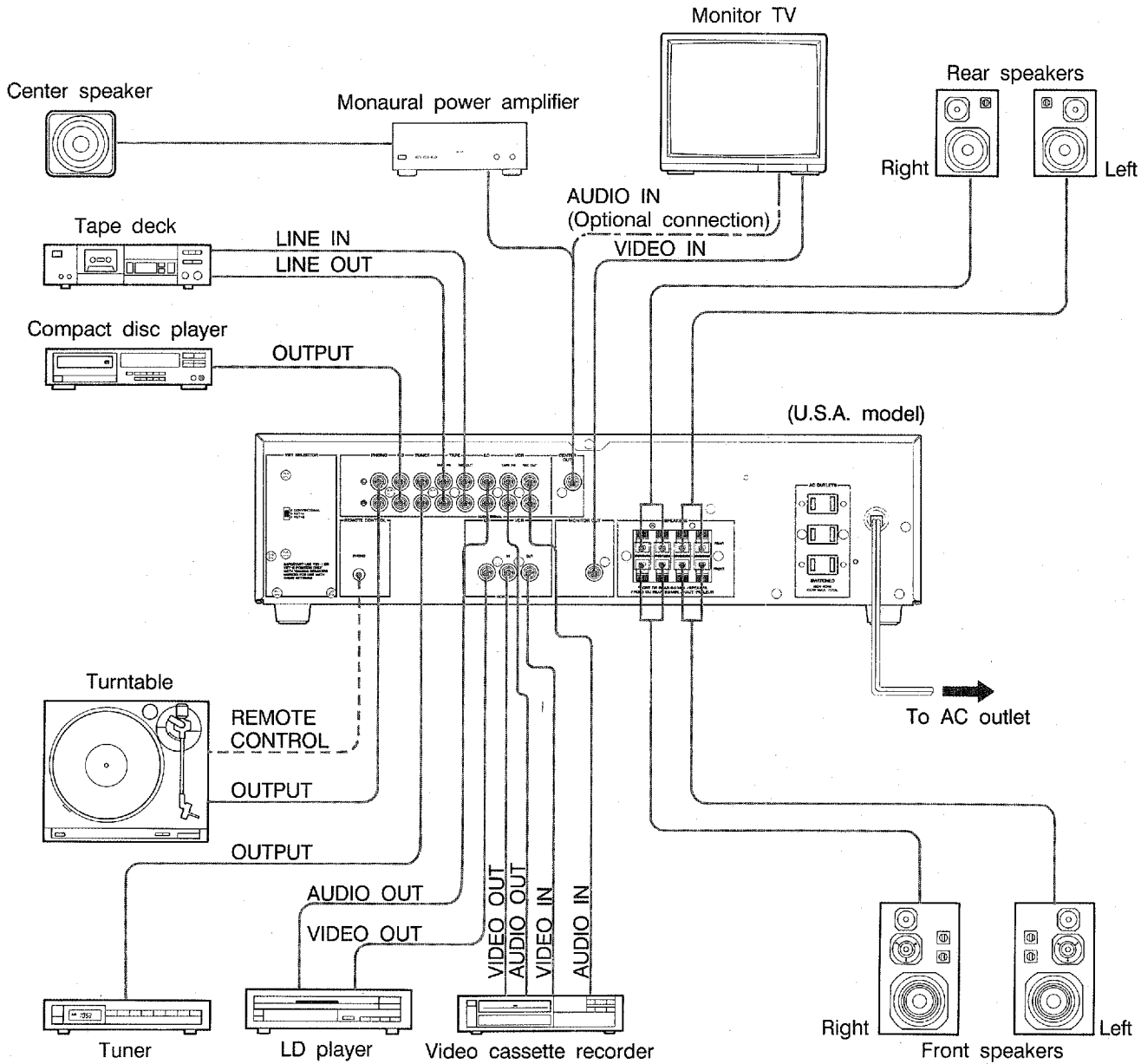

**Note :** A TV/Monitor which is equipped with audio inputs may be able to function as the center channel amplifier and loudspeaker. If desired, refer to the owner's manual of your TV/Monitor.

### Connecting speaker systems

Connect the **SPEAKERS** terminals to your speakers with wire of the proper gauge, cut to be as short as possible. If the connections are faulty, no sound will be heard from the speakers. Make sure that the polarity of the speaker wires is correct, that is, + and - markings are observed. If these wires are reversed, the sound will be unnatural and will lack bass. **Do not let the bare speaker wires touch each other or do not let them touch the metal parts of this unit as this could damage this unit and/or speakers.**

- Use speakers with the specified impedance shown on the rear of this unit.

#### • How to Connect Front and rear speakers:

Red: positive (+)  
Black: negative (-)

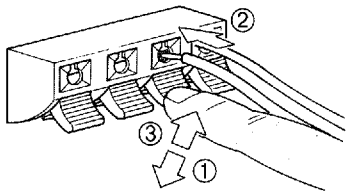

- ① Press and hold the tab.
- ② Insert the bare wire.
- ③ Release the tab and tighten the wire.

#### Center speaker:

Connect the input terminal of the monaural power amplifier to the **CENTER OUT** terminal on the rear panel of this unit.

\* Refer to the owner's manual of monaural power amplifier for information about connections between the center speaker and the monaural power amplifier.

### About the accessory terminals

#### • AC OUTLETS (SWITCHED)

Use these outlets to connect the power cords from your components to this unit.

The power to the **SWITCHED** outlets is controlled by this unit's **POWER** switch or the provided remote-control transmitter's **POWER** key. They will supply power to any component whenever this unit is turned on.

The maximum power (total power consumption of components) that can be connected to the **SWITCHED AC OUTLETS** is 100 watts.

#### • REMOTE CONTROL (PHONO) connector

If you have a YAMAHA turntable with the **ERS** mark, connect it to this connector by using the cable provided with the turntable. This connection allows you to control the turntable from the provided remote control transmitter.

### Grounding (For turntable use)

If hum is heard outstandingly when you use your turntable with this unit, grounding is necessary. Connect the ground wire of the turntable to any metal part of this unit's rear panel by using a screw mounted there.

### Setting of the YST SELECTOR

This unit can drive conventional speakers and YAMAHA Active Servo Processing speakers. Switch the **YST SELECTOR** (located on the rear panel of this unit) to the appropriate position referring to the following.

**CONVENTIONAL** position: Conventional speakers are adaptable.

**YST-1** position, **YST-2** position: YAMAHA Active Servo Processing speakers are adaptable. For detailed information on which type of speakers is appropriate to each position, refer to the rear panel of the speakers to be used.

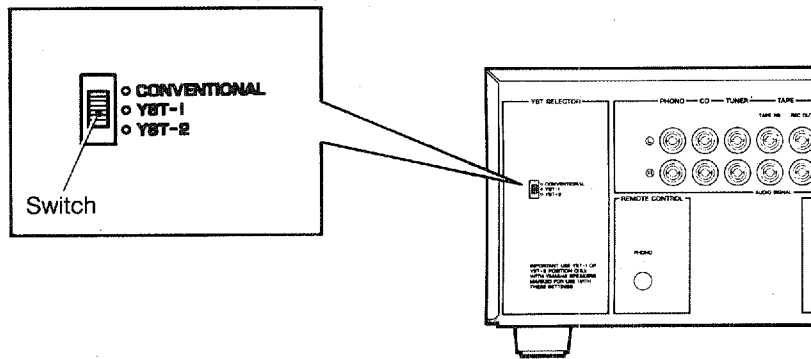

### Notes

- Incorrect connection or miss-setting of the switch could damage this unit and the connected speakers.
- Be absolutely sure that this unit's power is OFF before setting the switch and making the amplifier-to-speakers connections.



# SURROUND-SOUND PROCESSOR

This unit incorporates a sophisticated surround-sound processor. You can expand the audio sound field and enjoy a theater-like experience in the listening/viewing room.

## SURROUND MODES

**DD DOLBY PRO LOGIC SURROUND:** This unit employs the Dolby Pro Logic Surround system. This system is similar to professional Dolby stereo decoders used in movie theaters.

The Dolby Pro Logic Surround system, by employing a four-channel system, divides the input signals into four levels: the left and right main channels, the center channel (to characterize dialogue), and the rear surround-sound channels (to characterize sound effects, background noise and other ambient noise).

As a result, compared to the conventional 3-channel surround system, the yield of the true center channel is added, thus even further expanding the width of the surround-sound effect.

Dolby surround is encoded on the sound track of commercially available video cassettes and video discs as well. When you play a source encoded with Dolby surround on your home video system, the Dolby Pro Logic surround mode on this unit decodes the signal and feeds the surround-sound effects.

### Note

Be sure all equalizer's controls are set to the flat position when this unit is in the Dolby Pro Logic surround mode. Otherwise, Dolby Pro Logic playback will not be reproduced accurately.

### DD DOLBY SURROUND™

Manufactured under license from Dolby Laboratories Licensing Corporation. Additionally licensed under one or more of the following patents: U.S. numbers 3,632,886, 3,746,792, and 3,959,590; canadian numbers 1,004,603 and 1,037,877. "Dolby" and the double-D symbol are trademarks of Dolby Laboratories Licensing Corporation.

**NATURAL SURROUND:** The Natural Surround is an exclusive YAMAHA surround-sound processing mode which is effective with all music and audio sources of video sound. It creates a natural, lifelike surround-sound effect without the use of delay circuitry, adding considerable depth and imaging to all audio sources. It is recommended for both music listening and for viewing stereo video sources.

### Note

If a monaural sound source is used in the Dolby Pro Logic or Natural Surround mode, no sound will be heard from the rear speakers.

## SPEAKER SETTING TO ENJOY THE SURROUND-SOUND

In a full 5-speaker system you will use two pairs of speakers: **front speakers**, **rear speakers**, and a **center speaker**. The front speakers will probably be your present stereo speaker system. The rear and center speakers do not need to be of such high quality. But they should have high enough power handling to accept the maximum output of this unit that will drive them.

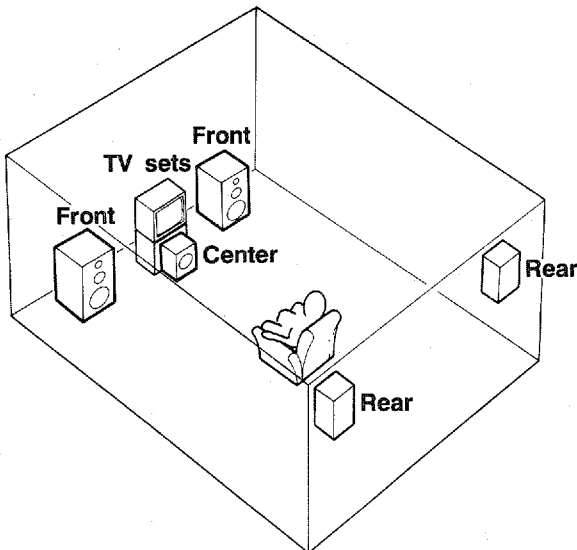

**Front:** In normal position. (The position of your present stereo speaker system.)

**Rear:** Behind your listening position, facing slightly inward. Nearly six feet up from the floor.

**Center:** Precisely between the front speakers. (To avoid interference to TV sets, use a magnetically shielded speaker. If, however, it is not effective, keep the speaker away from TV sets.)

# ADJUSTMENTS BEFORE OPERATION

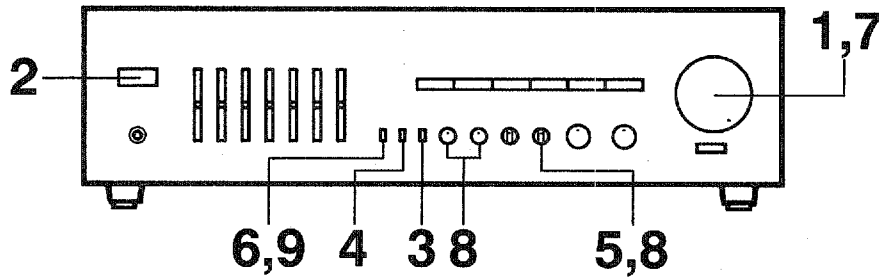

## Front/center/rear speaker balance adjustment

Using the built-in test tone generator, this procedure lets you adjust the volume balance between the front, center, and rear speakers. This adjustment is important for proper Dolby Pro Logic Surround-sound operation.

<p><b>1</b></p> <p>VOLUME</p> <p>Set to the "∞" position.</p>	<p><b>6</b></p> <p>TEST ON OFF → ON</p>
<p><b>2</b></p> <p>POWER</p>	<p><b>7</b></p> <p>Turn up the <b>VOLUME</b> control. You will hear a test tone (pink noise) from the right front speaker, then the center speaker, then the left front speaker, then the rear speakers, for about two seconds each.</p>
<p><b>3</b></p> <p>SURROUND MODE</p> <p>ON OFF → ON</p>	<p><b>8</b></p> <p>Adjust the <b>REAR</b> level and <b>CENTER</b> level controls so that the volume heard at the listening position is the same from each speaker.</p>
<p><b>4</b></p> <p>SURROUND MODE</p> <p>DOLBY PRO NATURAL → DOLBY PRO</p>	<p><b>9</b></p> <p>TEST ON OFF → OFF</p>
<p><b>5</b></p> <p>CENTER MODE</p> <p>Set to the "NORM" position.</p>	<p><b>Notes</b></p> <ul style="list-style-type: none"> <li>• Set <b>SURROUND MODE ON/OFF</b> switch to <b>OFF</b> when listening to the normal 2-channel stereo sound without surround-sound effect. No sound will be output from the rear speakers.</li> <li>• If not using a center speaker, in the step 5, be sure to set the front panel <b>CENTER MODE</b> selector to the <b>PHANTOM</b> position. You will then hear the center channel test tone from the left and right front speakers. <b>NORM</b> position is selected when you use a center speaker.</li> </ul>



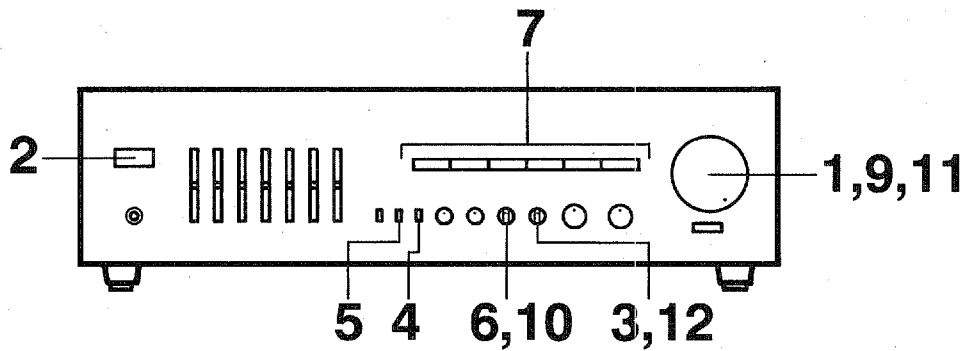

### Input balance control adjustment

This adjustment should be done to assure optimum performance of the Dolby Pro Logic Surround Decoder.

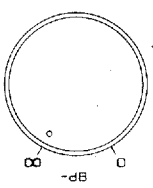
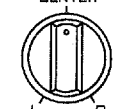
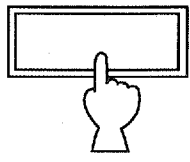
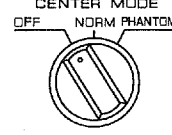
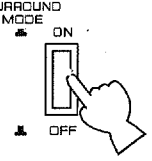
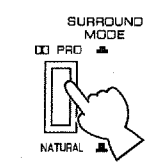
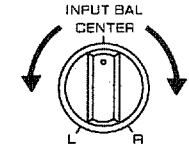
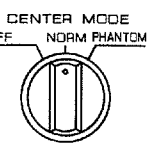
<p><b>1</b></p> <p style="text-align: center;">VOLUME</p>  <p style="text-align: center;">Set to the "∞" position.</p>	<p><b>6</b></p> <p style="text-align: center;">INPUT BAL CENTER</p>  <p style="text-align: center;">Set to the "CENTER" position.</p>
<p><b>2</b></p> <p style="text-align: center;">POWER</p> 	<p><b>7</b> Select a input source by using the input selector.</p>
<p><b>3</b></p> <p style="text-align: center;">CENTER MODE OFF NORM PHANTOM</p>  <p style="text-align: center;">Set to the "OFF" position.</p>	<p><b>8</b> Play the monaural portion (such as dialogue) of a program source encoded with Dolby surround.</p>
<p><b>4</b></p> <p style="text-align: center;">SURROUND MODE ON OFF</p>  <p style="text-align: center;">→ ON</p>	<p><b>9</b> Increase the <b>VOLUME</b> control setting so that you can hear the monaural program source through the rear speakers.</p>
<p><b>5</b></p> <p style="text-align: center;">SURROUND MODE DOLBY PRO NATURAL</p>  <p style="text-align: center;">→ DOLBY PRO</p>	<p><b>10</b> Then minimize the rear speakers' output by slightly turning the <b>INPUT BAL</b> control clockwise or counterclockwise until you achieve a "null" (i.e., minimum output from your rear speakers).</p> 
<p><b>11</b> As you approach the "null", increase the <b>VOLUME</b> control setting to better hear your rear speakers.</p>	<p><b>12</b></p> <p style="text-align: center;">CENTER MODE OFF NORM PHANTOM</p>  <p style="text-align: center;">Set to the "NORM" position.</p>

# OPERATIONS

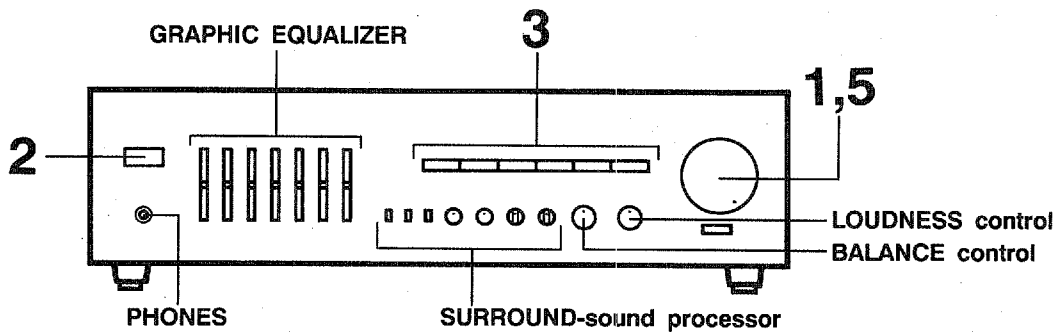

## To play a source

**1**

VOLUME

Set to the "∞" position.

---

**2**

POWER

---

**3** Select a desired source. (For video sources, turn the TV/monitor ON.)

VCR MON  LD  TAPE MON  TUNER  CD  PHONO

---

**4** Play the source.

**5**

VOLUME

Adjust to the desired output level.

---

**6** If desired, adjust the **BALANCE, LOUDNESS** controls and **GRAPHIC EQUALIZER**. (Refer to the corresponding page for details.)

### Notes

In the step 3, if you select two or more input sources at the same time (by using input selectors), note the following.

- If you select **LD, TUNER, CD** or **PHONO**, be sure that **TAPE MON** and/or **VCR MON** are not being pressed.
- If you select **TAPE MON** and **VCR MON** at the same time, the result will be the visual of the VCR and the sound from the audio tape.
- If you select both **LD** and **TAPE MON** at the same time, the result will be the visual of the LD player and the sound from the audio tape.
- Once you play the LD player, its visual will not be interrupted even if other input selectors except **VCR MON** are selected.
- If you select **VCR MON, TAPE MON**, and another input selector at the same time, the result will be the visual of the VCR and the sound from the audio tape.

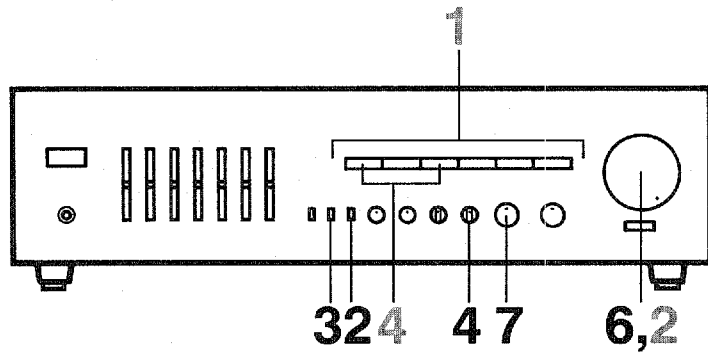

### To play a source with SURROUND-sound processor

### To record a source to tape

- 1 Follow the step 1, 2, and 3 shown in "To play a source".
- 2 → ON
- 3 → PRO or NATURAL
- 4 Set the **CENTER MODE** selector to the appropriate position, **NORM** or **PHANTOM**. (**NORM** is selected when you use a center speaker. **PHANTOM** is selected when you do not use a center speaker.)
- 5 Play the source.
- 6 → Adjust to the desired output level.
- 7 If desired, adjust the **BALANCE** control. (Refer to the corresponding page for details.)

- 1 Select the source to be recorded.
  - VCR MON  LD  TAPE MON  TUNER  CD  PHONO
  - \* When selecting **LD**, **TUNER**, **CD** or **PHONO**, be sure that **TAPE MON** and/or **VCR MON** are not being pressed.
  - \* It is not possible to record from the audio tape deck (**TAPE MON**) to the VCR (**VCR MON**).
- 2 Play the source and then turn the **VOLUME** control up to confirm the input source.
- 3 Set the tape deck or VCR in the recording mode.
- 4 By pressing the input selector for tape deck or VCR used for recording, you can monitor the audio or (and) video signals to be recorded.
  - VCR MON  LD  TAPE MON  TUNER  CD  PHONO

**Note**  
 Adjusting the **VOLUME**, **LOUDNESS**, **BALANCE** controls, **GRAPHIC EQUALIZER**, and **SURROUND-sound processor** during recording has no effect on the material being recorded.

**Note**  
 When playing a source with the **PRO** position selected, the **LOUDNESS** control and the **GRAPHIC EQUALIZER** should be set to the **FLAT** position.

### Adjusting the BALANCE control

Adjust the balance of the output volume to the left and right speakers to compensate for sound imbalance caused from the speaker settings or the listening room condition.

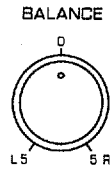

### Using GRAPHIC EQUALIZER controls

These seven independent slide controls are used to tailor, each over a  $\pm 10$  dB range, the overall output frequency response of the amplifier. The seven bands cover the complete audible sound spectrum and are centered on 60 Hz, 150 Hz, 400 Hz, 1 kHz, 2.5 kHz, 6.3 kHz and 16 kHz frequencies.

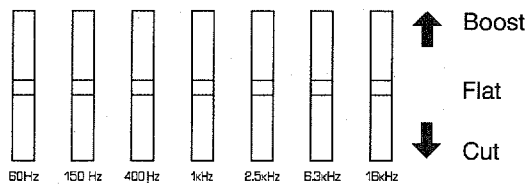

### Adjusting the continuous variable LOUDNESS control

This control provides compensation for the human ears' loss of sensitivity to high and low-frequency ranges at low volume. This control is adjustable to retain full tonal range at any volume level.

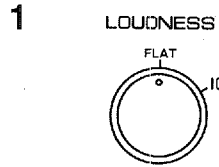

Set to the "FLAT" position.

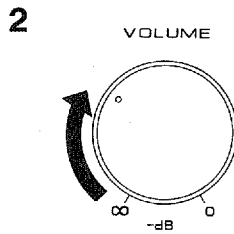

Set to the loudest listening level that you would listen to.

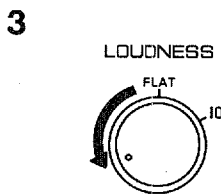

Turn so that the desired volume level can be achieved.

### When you listen with headphones

Connect the headphones to the PHONES jack when listening with headphones privately.

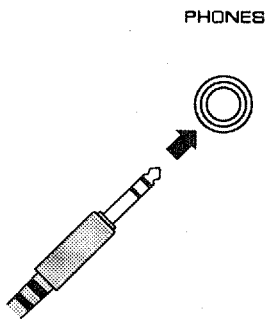

# REMOTE-CONTROL TRANSMITTER

The remote-control transmitter provided with this unit is designed to control all the most commonly used functions of the unit. If the CD player, turntable, LD player, tuner, and tape deck connected to this unit are YAMAHA components designed for remote control compatibility, then this remote-control transmitter will also control various functions of each component. Please consult YAMAHA dealer for information on which components are compatible with the remote-control transmitter.

## Key Functions

### For Amplifier Control

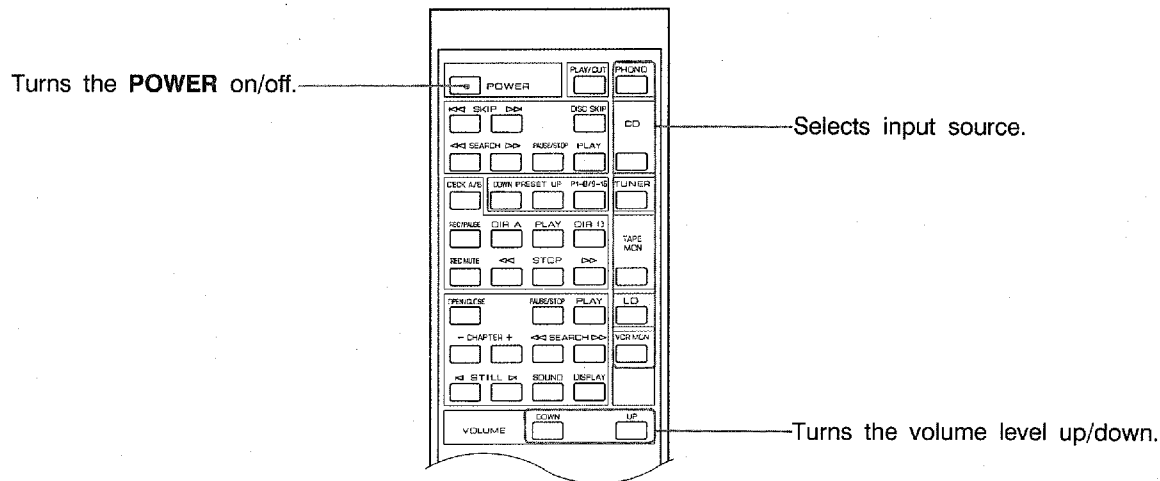

### For Other Component Control

Identify the remote-control transmitter keys with your component's keys. If these keys are identical, their function will be the same. On each key function, refer to the corresponding instruction on your component's manual.

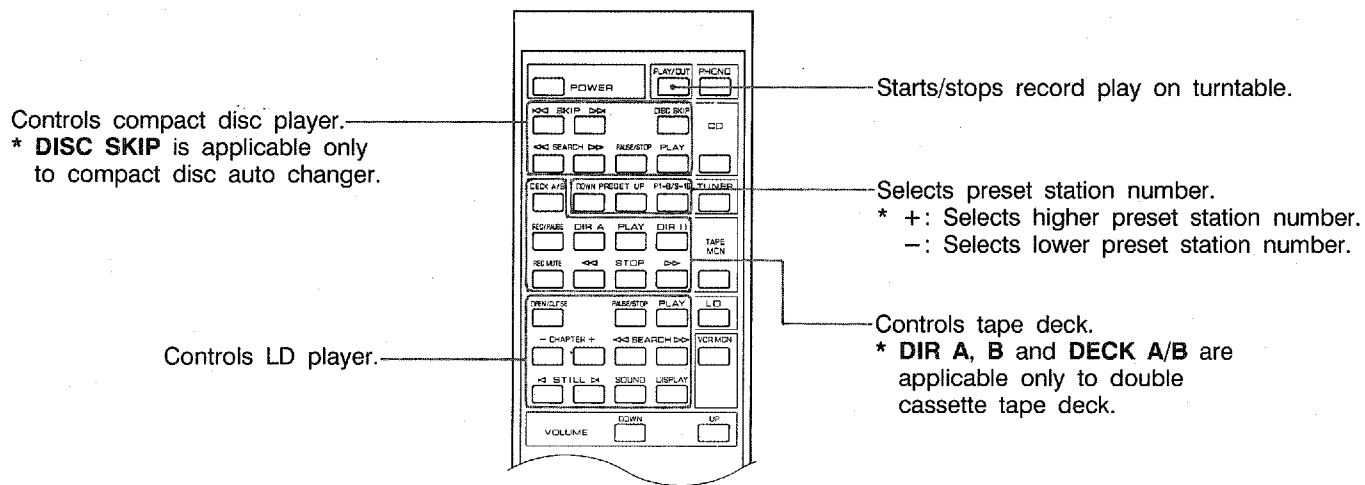

# NOTES ABOUT THE REMOTE CONTROL TRANSMITTER

## Battery installation

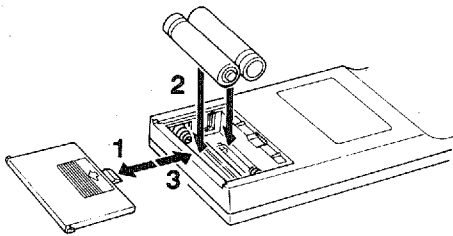

## Battery replacement

If the remote-control transmitter must be used closer to the main unit, the batteries are weak. Replace both batteries with new ones.

### Notes

- "AAA" (R03) batteries should be used for replacement.
- Be sure the polarities are correct. (See the illustration inside the battery compartment.)
- Remove the batteries if the remote-control transmitter will not be used for an extended period of time.
- If batteries leak, immediately dispose of them. Avoid touching the leaked material or letting it come in contact with clothing, etc. Clean the battery compartment thoroughly before installing new batteries.

## Remote-control transmitter operation range

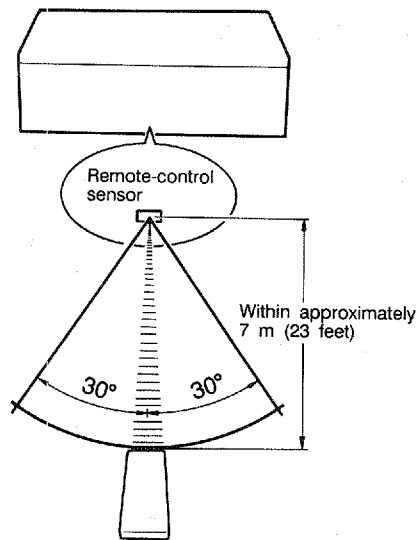

There should be no large obstacles between the remote-control transmitter and the main unit.

# TROUBLESHOOTING

Before assuming that your unit is faulty, please check the following troubleshooting list, which details corrective actions you can take yourself without calling a service engineer. If you have any questions, contact your nearest Yamaha dealer.

PROBLEM	POSSIBLE CAUSES	REMEDY
Power is not supplied even though the POWER switch is ON.	The power plug is not securely connected.	Connect it securely.
There is no sound or no picture when any input selector is pressed.	The input wires are not connected securely.	Connect them securely.
	The speaker systems are not connected correctly.	Check and secure the connections.
There is no sound from one speaker.	The speaker connections are not secure.	Secure the connections.
	The BALANCE control is set all the way to the left or right.	Adjust the BALANCE control correctly.
There is a lack of bass, and no ambience.	The + and - wires are connected in reversed at the amplifier or speakers.	Connect the speaker wires in the correct phase (+ and -).
There is a humming sound when playing records.	The input wires are not connected securely.	Connect the input wires securely.
There is a howling sound when playing records at high volume.	The turntable and the speakers are too close together, or the turntable is not located on a firm surface.	Change the location of the turntable or the speakers.
The sound suddenly stops.	Using outside the rated impedance range at high power for an extended period has activated the speaker protection circuit.	Switching this unit OFF and then ON will reset the speaker protection circuit. Use speakers within the rated impedance range.
	There is a malfunction in the amplifier.	Consult your Yamaha dealer.

# SPECIFICATIONS

Minimum RMS Output Power Per Channel  
 Front (20 Hz - 20 kHz 0.1% THD 8Ω) ... 100W  
 Rear (1 kHz 1% THD 8Ω) ..... 15W

Dynamic Power Per Channel  
 (by IHF Dynamic Headroom Measuring Method)  
 8Ω/6Ω ..... 140W/180W

Dynamic Headroom  
 8Ω ..... 1.6 dB

Damping Factor  
 1 kHz 8Ω ..... 50

Input Sensitivity/Impedance  
 Phono MM ..... 2.5 mV/47 kΩ  
 CD/TUNER/TAPE/LD/VCR ..... 150 mV/47 kΩ

Input Sensitivity (New IHF)  
 Phono MM ..... 0.25 mV  
 CD/TUNER/TAPE/LD/VCR ..... 15 mV

Maximum Input Signal (1 kHz 0.15% THD)  
 Phono MM ..... 80 mV

Output Level/Impedance  
 REC OUT ..... 150 mV/1.4 kΩ  
 CENTER OUT ..... 1.75V/4.4 kΩ

Headphone Jack Rated Output/Impedance  
 Output Level, 0.1% THD RL=8Ω ..... 180 mV  
 Impedance ..... 150Ω

Frequency Response (20 Hz - 20 kHz)  
 CD/TUNER/TAPE/LD/VCR  
 ..... 20 Hz - 20 kHz, -0.5±0.5 dB

RIAA Equalization Deviation  
 Phono MM ..... 0±0.5 dB

Total Harmonic Distortion (20 Hz - 20 kHz)  
 Phono MM to REC OUT, 3V ..... 0.01%  
 CD/TUNER/TAPE/LD/VCR to SP OUT,  
 50W/8Ω ..... 0.05%

Signal-to-Noise Ratio (IHF-A Network)  
 Phono MM (5 mV Input Shorted) ..... 79 dB  
 CD/TUNER/TAPE/LD/VCR (Shorted) ..... 92 dB

Residual Noise (IHF-A Network) ..... 230 μV

Channel Separation Vol -30 dB  
 Phono MC, MM Input shorted  
 1 kHz/10 kHz ..... 52 dB/50 dB  
 CD/TUNER/TAPE/LD/VCR Input 5.1 kΩ  
 Terminated  
 1 kHz/10 kHz ..... 52 dB/50 dB

Graphic Equalizer (boost/cut 60 Hz, 150 Hz, 400  
 Hz, 1 kHz, 2.5 kHz, 6.3 kHz, 16 kHz)  
 ..... ±10 dB

Continuous Loudness Control (Level Related  
 Equalization)  
 Attenuation ..... -20 dB (1 kHz)

Gain Tracking Error (0 - -60 dB)  
 ..... Less than 3 dB

Video Input/Output ..... 1 Vp-p/75Ω

Power Supply ..... AC 120V/60 Hz

Power Consumption  
 U.S.A. model ..... 230W  
 Canada model ..... 320W, 410 VA

AC Outlets  
 3 SWITCHED OUTLETS ..... 100W max. total

Dimensions (W x H x D)  
 ..... 435 x 122.5 x 304.7 mm  
 (17-1/8" x 4-13/16" x 12")

Weight ..... 8.7 kg (19 lbs. 2 oz.)

\* Specifications are subject to change without  
 notice.

\* This product complies with the radio  
 frequency interference requirements of the  
 Council Directive 82/499/EEC and/or  
 87/308/EEC.



# YAMAHA

---

**YAMAHA ELECTRONICS CORPORATION, USA** 6722 ORANGETHORPE AVE., BUENA PARK, CALIF. 90620, U.S.A.  
**YAMAHA CANADA MUSIC LTD.** 135 MILNER AVE., SCARBOROUGH, ONTARIO M1S 3R1, CANADA  
**YAMAHA ELECTRONIK EUROPA G.m.b.H.** SIEMENSSTR. 22-34, D-2084 RELLINGEN BEI HAMBURG, F.R. OF GERMANY  
**YAMAHA ELECTRONIQUE FRANCE S.A.** 17 RUE DES CAMPANULES, LOGNES 77321 MARNE LA VALLEE CEDEX 2, FRANCE  
**YAMAHA ELECTRONICS (UK) LTD.** YAMAHA HOUSE, 200 RICKMANSWORTH ROAD WATFORD, HERTS WD1 7JS, ENGLAND  
**YAMAHA SCANDINAVIA A.B.** J A WETTERGRENS GATA 1, BOX 30053, 400 43 VASTRA FRÖLUNDA, SWEDEN  
**YAMAHA MUSIC AUSTRALIA PTY, LTD.** 17-33 MARKET ST., SOUTH MELBOURNE, 3205 VIC., AUSTRALIA

**YAMAHA CORPORATION**

VK45960-0 BWB ℓ, BB ℓ ① ② Printed in Japan