

# YAMAHA KX-670

*Natural Sound Stereo Cassette Deck*

*Platine à cassette stéréo de la série "Natural Sound"*

*"Natural Sound" Stereo-Kassettengerät*

*Natural Sound stereokassettdäck*

*Registratore a cassette stereo a suono naturale*

*Magnetófono estéreo de sonido natural*

*Stereo-cassettedeck voor een "natuurlijk geluid"*

**CENTER**

OWNER'S MANUAL  
MODE D'EMPLOI  
BEDIENUNGSANLEITUNG  
BRUKSANVISNING  
MANUALE DELL'UTENTE  
MANUAL DE INSTRUCCIONES  
GEBRUIKSAANWIJZING

## **CAUTION: READ THIS BEFORE OPERATING YOUR UNIT.**

1. This unit is a sophisticated stereo cassette deck. To ensure proper operation for the best possible performance, please read this manual carefully.
2. Choose the installation location of your unit carefully. Avoid placing it in direct sunlight or close to source of heat. Also avoid locations subject to vibration and excessive dust, heat, cold or moisture. Keep it away from sources of hum such as transformers or motors.
3. Do not open the cabinet as this may result in damage to the deck or electrical shock. If a foreign object should get into the deck, contact your local dealer.
4. When removing the power plug from the wall outlet, always pull directly on the plug; never pull the cord itself.
5. Do not apply excessive force when operating switches and knobs.
6. When moving the deck, be sure to first pull out the power plug and remove all cords connecting the deck to other equipment.
7. Do not attempt to clean this unit with chemical solvents as this may damage the finish. Use a clean, dry cloth.
8. Never allow metallic items (e.g. screwdrivers, tools, etc.) to come near the record/playback head assembly. Doing so may not only scratch or damage the head's mirror-smooth finish, it may also change the magnetic characteristics of the heads, causing a deterioration in reproduction quality.
9. Although the record/playback head used in this unit is a high quality head with outstanding reproduction characteristics, it can become dirty through the use of old tapes or from dust accumulation over time. This can have a serious effect on reproduction quality. Clean the heads regularly with one of the commonly available head cleaners or with cleaning solutions as explained later in this manual.
10. Be sure to read the "Troubleshooting" section of this manual for advice on common operating errors before concluding that your unit is faulty.
11. Keep this manual in a safe place for future reference.
12. **Voltage Selector (General Model only)**  
**The voltage selector on the rear panel of this unit must be set for your local mains voltage BEFORE plugging in the AC mains supply.**

Please check the copyright laws in your country to record from records, compact discs, radio, etc. Recording of copyright material may infringe copyright laws.

### **WARNING**

TO REDUCE THE RISK OF FIRE OR ELECTRIC SHOCK, DO NOT EXPOSE THIS APPLIANCE TO RAIN OR MOISTURE.

### **Special Instructions for U.K. Model**

#### **IMPORTANT**

The wires in the mains lead are coloured in accordance with the following code:

Blue: NEUTRAL  
Brown: LIVE

As the colours of the wires in the mains lead of this apparatus may not correspond with the coloured markings identifying the terminals in your plug, proceed as follows. The wire which is coloured BLUE must be connected to the terminal which is marked with the letter N or coloured BLACK. The wire which is coloured BROWN must be connected to the terminal which is marked with the letter L or coloured RED. Making sure that neither core is connected to the earth terminal of the three pin plug.

### **Special Instructions for Canada Model**

THIS DIGITAL APPARATUS DOES NOT EXCEED THE "CLASS B" LIMITS FOR RADIO NOISE EMISSIONS FROM DIGITAL APPARATUS SET OUT IN THE RADIO INTERFERENCE REGULATION OF THE CANADIAN DEPARTMENT OF COMMUNICATIONS.

**CAUTION:** TO PREVENT ELECTRIC SHOCK, MATCH WIDE BLADE OF PLUG TO WIDE SLOT, FULLY INSERT.

## TABLE OF CONTENTS

FEATURES .....	3	RECORDING .....	9
CONNECTIONS .....	4	VARIOUS FUNCTIONS HELPFUL FOR HIGH QUALITY	
PLAYBACK .....	5	RECORDING .....	11
SELECTION SEARCH .....	7	REC MUTE OPERATION .....	12
INTRO SCAN .....	7	REC RETURN OPERATION .....	12
MEMORY STOP .....	8	0-STOP OPERATION .....	12
REPEAT PLAYBACK .....	8	TIMER RECORDING/PLAYBACK .....	13
		CASSETTE TAPES .....	14
		MAINTENANCE .....	15
		OPTIONAL REMOTE CONTROL TRANSMITTER .....	15
		TROUBLESHOOTING .....	16
		SPECIFICATIONS .....	18

## FEATURES

- 3-Head Configuration
- Dolby HX Pro Dynamic Bias Servo
- Dolby B/C Noise Reduction
- Auto Tape Tuning improves the quality of recording by automatically adjusting the recording characteristics (recording bias and sensitivity) for best result with every cassette tape
- Fine Adjustment of Recording Bias with Bias Adjust Control allows you to compensate the high frequency sound as your liking
- Play Trim Control for Improved Playback Compatibility with Other Decks
- Full, 0-M Repeat Play, Memory Stop Function, Selection Search and Bi-Directional Intro Scan
- Recording Mute Function
- Rec Return/0-stop Function
- Integrated System Remote Control Compatibility

## CONNECTIONS

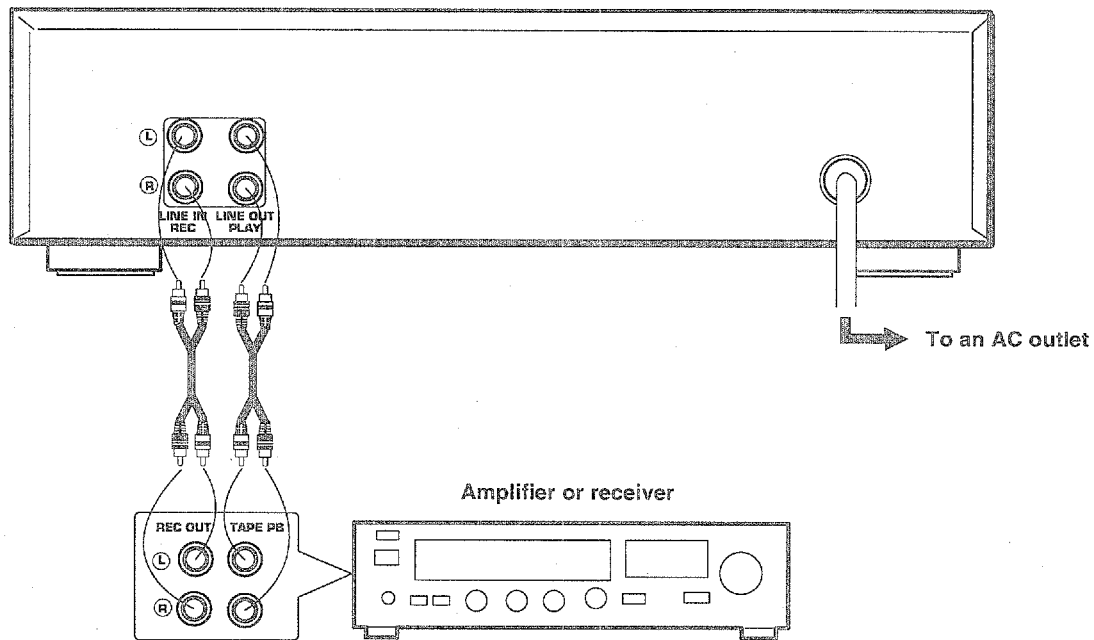

### REAR PANEL CONNECTIONS

Make sure that power to both the deck and your amplifier/receiver are turned off before making any connection.

- The White plug on the paired connecting cables corresponds to the Left channel and the Red plug corresponds to the Right channel. Make sure that the left and right channel connections are properly made, and that the plugs are inserted firmly.
- The LINE OUT/PLAY jacks on the deck should be connected to the Tape PB (Playback/Input) jacks on your amplifier/receiver, and the LINE IN/REC jacks on the deck should be connected to the Rec Out (Rec/Output) jacks on your amplifier/receiver.
- Connect the power cord to an AC wall outlet or to an AC outlet on the rear panel of your amplifier/receiver (if provided).

# PLAYBACK

## Preparation for playback

- Turn on the POWER switch.
- Set your amplifier or receiver to cassette deck function mode.

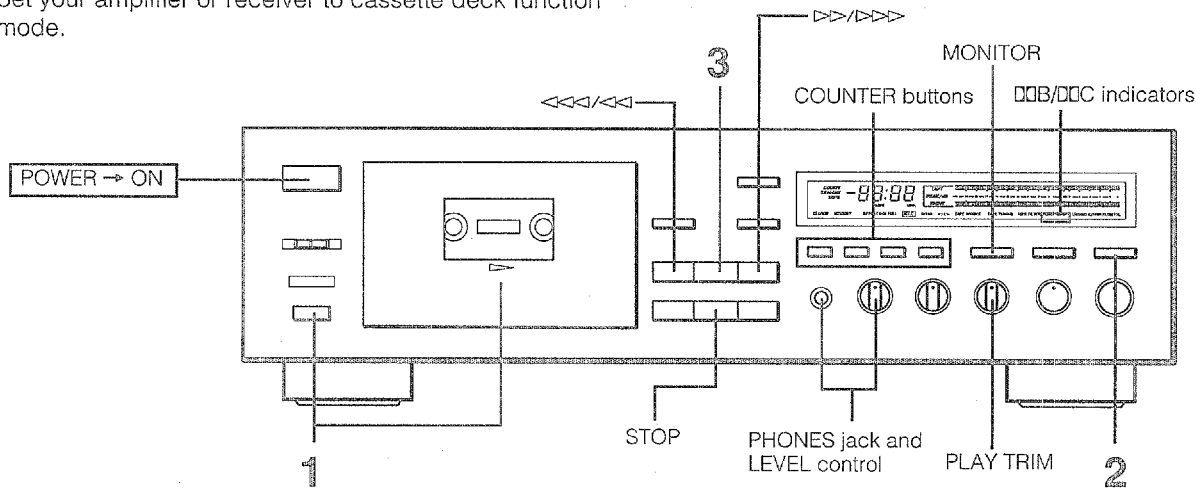

<p><b>1</b></p> <p>Insert the cassette with the exposed tape side facing down and the side to be played facing you. To close the compartment, push in the compartment door until it locks shut.</p>	<p><b>2</b></p> <p>Refer to "DOLBY NR button setting".</p>	<p><b>3</b></p>
---	--	-----------------

### DOLBY NR button setting (in step 2)

Be sure to set the DOLBY NR button according to the system used for recording. Each time this button is pressed, Dolby NR switches to 00B (MPX OFF), to 00C (MPX OFF), to 00B MPX ON, to 00C MPX ON, to OFF and back around to 00B (MPX OFF).

### For a tape recorded with DOLBY B NR (even for a tape recorded with DOLBY B NR and MPX ON):

Press this button so that only the 00B indicator lights.

### For a tape recorded with DOLBY C NR (even for a tape recorded with DOLBY C NR and MPX ON):

Press this button so that only the 00C indicator lights.

### For a tape recorded with DOLBY NR OFF:

Set this button so that no indicator lights.

### Note:

The MPX filter settings are explained on page 9.

\* Dolby noise reduction manufactured under license from Dolby Laboratories Licensing Corporation. "DOLBY" and the double-D symbol are trademarks of Dolby Laboratories Licensing Corporation.

### To fast forward the tape

Press the button and keep pressing for more than 2 seconds to advance at high speed.

### To fast rewind the tape

Press the button and keep pressing for more than 2 seconds to rewind at high speed.

### To adjust the volume level

Use the volume control of the amplifier or receiver.

### To use headphones for private listening

Insert the headphones plug into the PHONES jack and adjust the volume with LEVEL control.

### To stop playback and remove the cassette tape

Press the STOP button and then the EJECT button. The cassette compartment comes out and you can remove the cassette tape. After removing it, push in the compartment door until it locks shut.

### Note:

Do not turn off the power while the tape is running. Otherwise, the EJECT button cannot be operated. In this case, press the POWER button to turn on the power and then the STOP button. The EJECT button can now be operated.

**Display during playback**

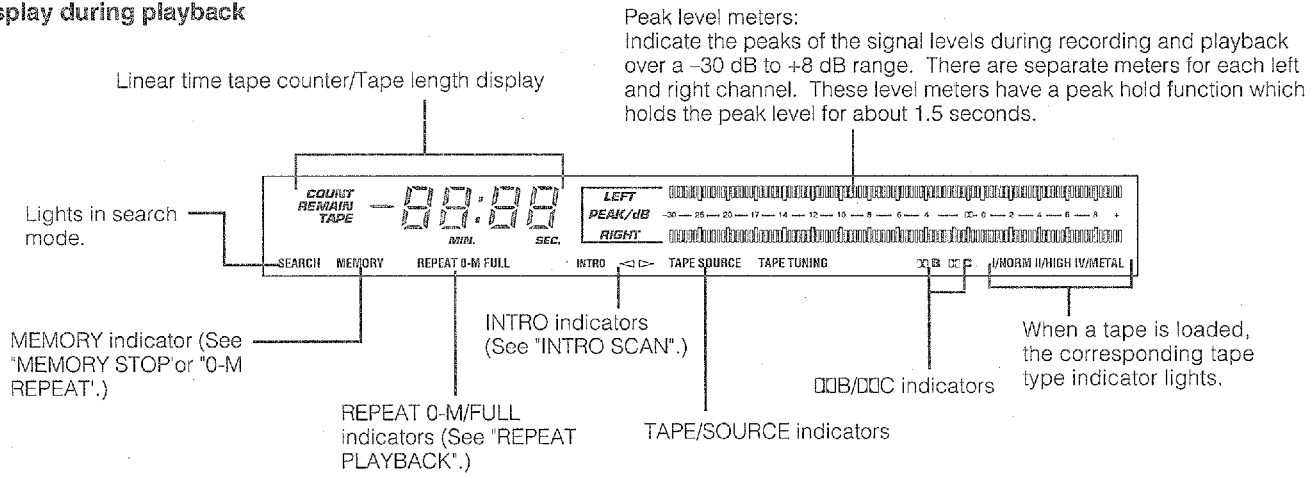

**Linear time tape counter and the tape length setting**

Use the linear time tape counter as an aid in locating a point on a tape (-99 min. 59 sec. to 99 min. 59 sec.). To set the counter reading to "0:00", press the COUNTER RESET button. This counter is not an actual clock. Rather, it is a counter with minutes and seconds divisions when the tape length of the tape to be used is memorized. To memorize the tape length, press the TAPE button so that the desired tape length appears on the display. The tape length can be set to C60, C90, C46 or C46L.

**Note: Precision of counter**

The tape counter is not a clock, and so there will be some errors in the time display compared to the actual playing time (this cannot be avoided, as a suitable method is adopted to provide a time display not only during recording and playback, but also during fast forward and rewind). The error depends on the type of tape being used.

**To display the remaining time**

Press REMAIN button. The REMAIN indicator lights and the display shows the remaining time. Press again to return to the elapsed time.

- It is necessary to memorize the tape length with the TAPE button beforehand.

**Notes on the monitor function**

During playback, the deck automatically selects the tape monitor mode. (The TAPE indicator lights.) If the monitor mode is switched to the source monitor mode by pressing the MONITOR button, no sound is heard. (The SOURCE indicator lights.)

During playback, be sure to set the MONITOR button so that the TAPE indicator lights.

**PLAY TRIM control adjustment**

When distortion or the absence of high frequencies is noticeable when playing a tape recorded on another cassette deck, compensate the high frequency response with the PLAY TRIM control.

When distortion is noticeable, attenuate the high frequencies.

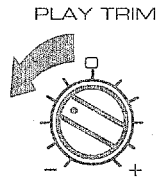

When high frequencies are absent, boost the high frequencies.

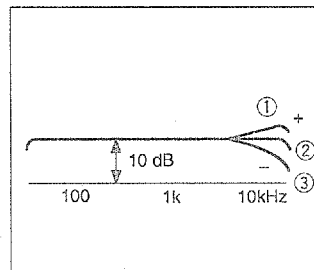
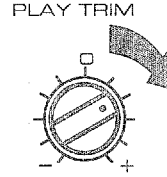

- ① High frequency sound is distorted.
- ② Flat
- ③ High-frequency sound is absent.

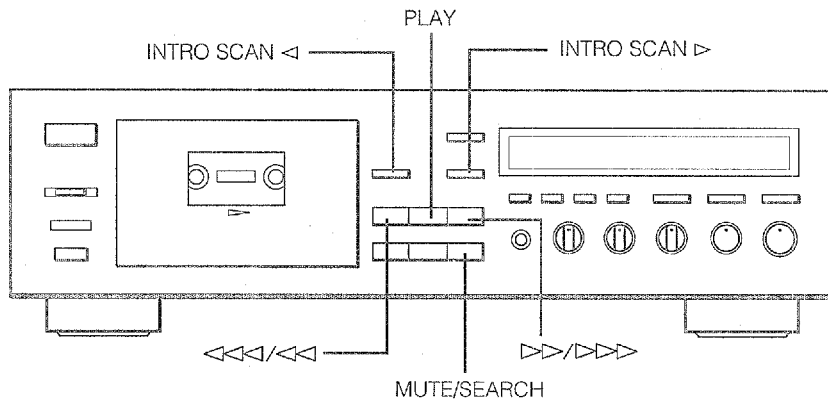

**SELECTION SEARCH - To play back a desired selection by searching for the beginning of the selection**

**INTRO SCAN - To play back the beginning of each selection automatically**

To search for the next selection

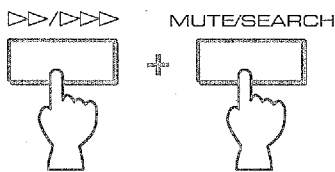

The >>>/>>> button and the MUTE/SEARCH button should be pressed simultaneously.

To search for the beginning of the current selection

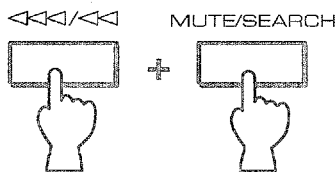

The <<</<<< button and the MUTE/SEARCH button should be pressed simultaneously.

To search for the selection located before the current selection

When the beginning of the current selection is played:

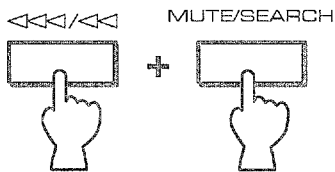

The <<</<<< button and the MUTE/SEARCH button should be pressed simultaneously.

To play back each selection in the reverse direction

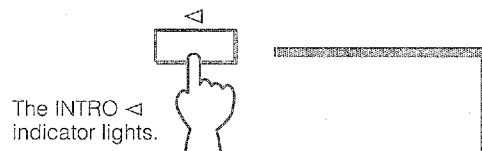

To play back each selection in the forward direction

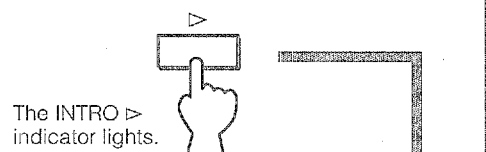

To resume normal playback when the desired selection is found

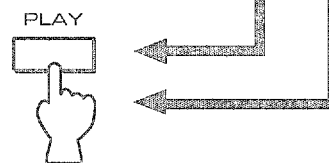

**Notes on Selection search and Intro scan**

- The blank section between selections must be at least 4 seconds.
- With tapes recorded with low level or having excessive noise, these operations may not be carried out.



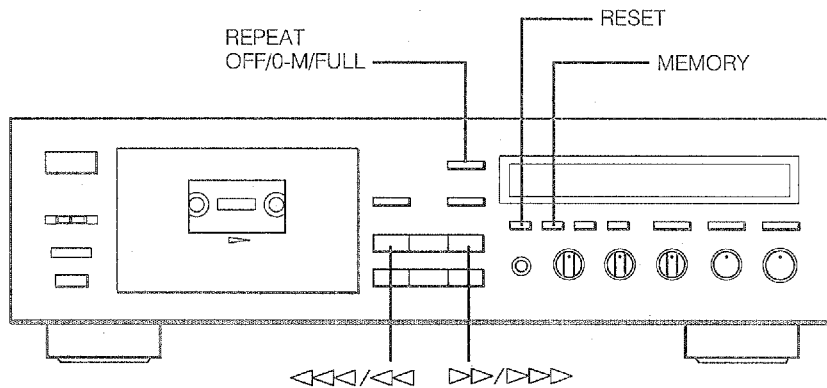

## MEMORY STOP - To return to the desired position

Pressing the MEMORY button memorizes the current counter reading. The MEMORY indicator lights.

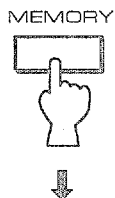

During fast forwarding or rewinding, the tape will stop at the counter reading point where the MEMORY button was pressed.

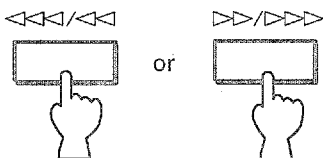

**Note:**  
To carry out the Memory Stop function correctly, the <<<< or >>>> button should not be pressed until at least 5 seconds have elapsed since the MEMORY button was pressed.

**To cancel the memorized counter reading**  
Press the MEMORY button again. The MEMORY indicator goes out.

## REPEAT PLAYBACK

**Full repeat playback**  
With this function, the side being played can be repeated up to 8 times.  
Press the REPEAT OFF/0-M/FULL button so that the REPEAT FULL indicator lights.

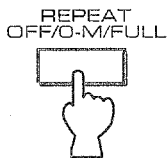

**0-M repeat playback**  
With this function, a desired section can be played repeatedly up to 8 times.

**1 Press the REPEAT OFF/0-M/FULL button so that the REPEAT 0-M indicator lights.**

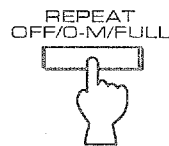

**2 Press the RESET button at the beginning of the section you want to play repeatedly.**



The counter reads "0:00".

**3 Press the MEMORY button at the end of the section.**



The MEMORY indicator lights.

The tape is rewound to the point where the RESET button was pressed and then the deck enters playback mode. The deck plays until it reaches the specified end of the section, rewinds to the beginning, and plays again.

**Note:**  
The length between the beginning and end points should be more than 5 seconds.

**To change the beginning and end points**  
When the RESET button is pressed again, the memorized points are canceled and the MEMORY indicator goes out. Specify the desired beginning point and end point with the RESET button and MEMORY button.  
To change only the end point, press the MEMORY button once to cancel the memorized end point and then press it again at the desired point.

**To cancel repeat playback**  
Press the REPEAT OFF/0-M/FULL button so that the REPEAT 0-M and REPEAT FULL indicators go out.







# RECORDING

ENGLISH

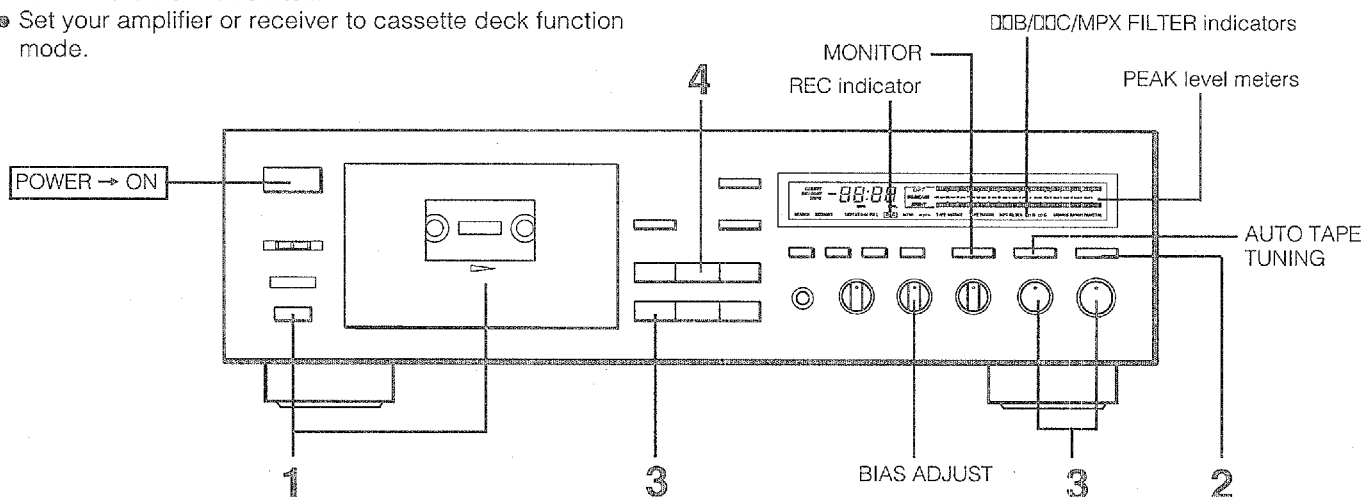
## Preparation for recording

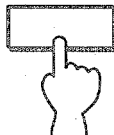
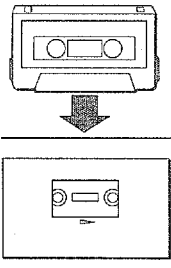
- Turn on the POWER switch.
- Set your amplifier or receiver to cassette deck function mode.

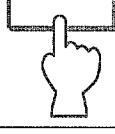

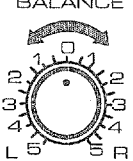
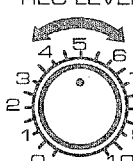
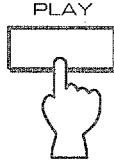
<p><b>1</b></p>   <p>Insert the cassette with the exposed tape side facing down and the side to be recorded facing you. To close the compartment, push in the compartment door until it locks shut.</p>	<p><b>2</b></p>  <p>Refer to "DOLBY NR button setting".</p>
<p><b>3</b></p>   <p>Play the program source to be recorded and adjust the recording level. See "Setting the recording level".</p>  	<p><b>4</b></p> 

### DOLBY NR button setting (in step 2)

Dolby noise reduction is an extremely effective method of reducing undesirable background hiss on tapes. This unit incorporates both Dolby B NR and the newer Dolby C NR system. Dolby C NR is approximately twice as effective as the earlier Dolby B NR.

Each time this button is pressed, Dolby NR switches to  $\square\square$ B (MPX OFF), to  $\square\square$ C (MPX OFF), to  $\square\square$ B MPX ON, to  $\square\square$ C MPX ON, to OFF and back around to  $\square\square$ B (MPX OFF).

### Recording sources other than FM broadcasts with DOLBY NR

#### With DOLBY B NR:

Press the DOLBY NR button so that only the  $\square\square$ B indicator lights. Make sure that the MPX FILTER indicator is not lit.

#### With DOLBY C NR:

Press the DOLBY NR button so that only the  $\square\square$ C indicator lights. Make sure that the MPX FILTER indicator is not lit.

### Recording an FM broadcast with DOLBY NR

#### With DOLBY B NR:

Press the DOLBY NR button so that the MPX FILTER and  $\square\square$ B indicators light.

#### With DOLBY C NR:

Press the DOLBY NR button so that the MPX FILTER and  $\square\square$ C indicators light.

#### No noise reduction:

Set this button so that no indicator lights.

#### MPX filter

FM stations transmit a 19 kHz pilot signal in addition to the broadcast program. Sometimes this pilot signal may leak into the audio output depending on the tuner and broadcast conditions. This signal can cause improper operation of the Dolby NR systems. Activating the MPX filter (B TYPE/C TYPE MPX ON settings) will effectively remove the signal.

## Display during recording

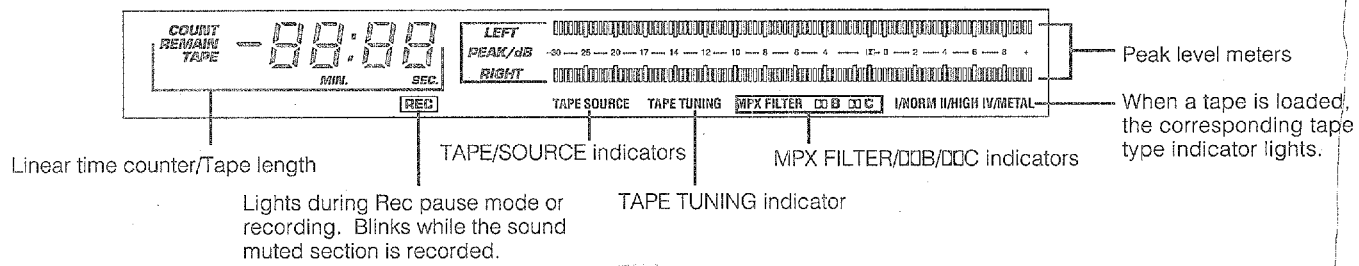

### Setting the recording level (in step 3)

Play the loudest passage of the source to be recorded and watch the meter readings. When using Normal position tapes (type I/NORM) or High position tapes (type II/HIGH (CrO<sub>2</sub>)), adjust the REC LEVEL control so that the highest peak is +4 dB. When using Metal position tapes (type IV/METAL), adjust the REC LEVEL control so that the highest peak is +6 dB. (Refer to the figure below.) Normally, it is best to adjust the BALANCE control such that the LEFT and RIGHT meter readings are even.

Highest peak for Normal or High position tapes

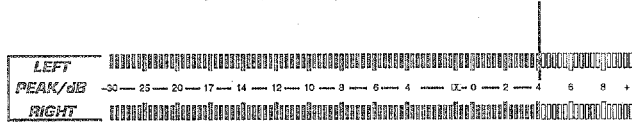

Highest peak for Metal position tapes

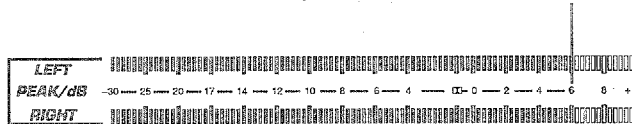

### Linear time tape counter and the tape length setting

Use the linear time tape counter as an aid in locating a point on a tape (-99 min. 59 sec. to 99 min. 59 sec.). To set the counter reading to "0:00", press the COUNTER RESET button. This counter is not an actual clock. Rather, it is a counter with minutes and seconds divisions when the tape length of the tape to be used is memorized. To memorize the tape length, press the TAPE button so that the desired tape length appears on the display. The tape length can be set to C60, C90, C46 or C46L.

#### Note: Precision of counter

The tape counter is not a clock, and so there will be some errors in the time display compared to the actual recording time (this cannot be avoided, as a suitable method is adopted to provide a time display not only during recording and playback, but also during fast forward and rewind). The error depends on the type of tape being used.

### To display the remaining time

Press REMAIN button. The REMAIN indicator lights and the display shows the remaining time. Press again to return to the elapsed time.

- It is necessary to memorize the tape length with the TAPE button beforehand.

### To stop recording temporarily

Press the REC/PAUSE button. To resume recording, press the PLAY button.

### To stop recording and remove the cassette tape

Press the STOP button and then the EJECT button. The cassette compartment comes out and you can remove the cassette tape. After removing it, push in the compartment door until it locks shut.

#### Note:

Do not turn off the power while the tape is running. Otherwise, the EJECT button cannot be operated. In this case, press the POWER button to turn on the power and then the STOP button. The EJECT button can now be operated.

### Three head system

The three-head system allows the just-recorded sound to be monitored while recording. You can compare the difference between the recorded sound and the source sound by switching the monitor mode (SOURCE or TAPE) with the MONITOR button, so you can try to obtain a recording sound identical to the source sound.

### To monitor the just recorded sound



### To monitor the sound to be recorded

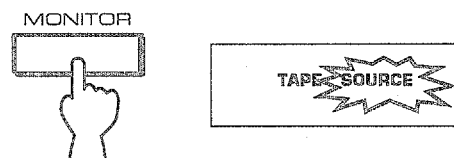

## VARIOUS FUNCTIONS HELPFUL FOR HIGH QUALITY RECORDING

This deck has a built-in Auto Tape Selector which automatically adjusts the recording characteristics according to the tape formulation (see page 15) and a Dolby HX Pro Dynamic Bias Servo System which automatically controls the effective bias during recording. In addition to these functions, you can refine your recordings, by using the Auto Tape Tuning function which adjusts the recording bias and sensitivity for each tape you use.

Also, the Bias Adjustment with the BIAS ADJUST control is possible even after auto tape tuning.

### Auto tape tuning function

The auto tape tuning function improves the quality of recording, permitting critical adjustment of the deck's recording bias and sensitivity for best results with every tape you use.

With the auto tape tuning function, the recording characteristics (recording bias and sensitivity) are automatically adjusted in three frequency ranges (100 Hz, 3 kHz and 10 kHz) while repeating recording and playback operations several times in about 8 seconds, to accurately match the characteristics of the loaded tape.

For example, the recorded (output) level (A) in the figure may differ from the recording (input) level (B) in the figure, due to widely varying characteristics between brands of cassette tape.

Using the auto tape tuning function, these differences are effectively eliminated by adjusting the recording bias (for high frequencies) and sensitivity (for overall frequencies) according to the loaded cassette tape, making a significant contribution to overall recording quality (C) in the figure.

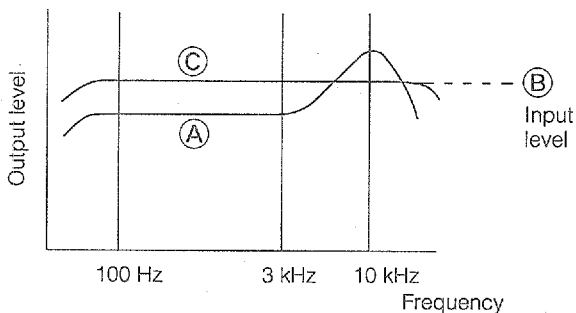

### <Operation>

1. Set the **PLAY TRIM** control and **BIAS ADJUST** control to the center position.
2. Press the **REC/PAUSE** button to enter the rec pause mode and adjust the recording level.
3. Press the **AUTO TAPE TUNING** button.

The TAPE TUNING indicator blinks and the deck determines the optimum recording characteristics (bias and recording sensitivity) according to the loaded cassette tape in about 5 seconds. After completion of Auto Tape Tuning, the tape is automatically rewound to the point where auto tape tuning began and the deck enters the rec pause mode. The TAPE TUNING indicator lights up.

- Auto tape tuning may not function with a poor quality tape. In this case, the TAPE TUNING indicator does not light up.
- The adjusted recording characteristics are not canceled as long as the TAPE TUNING indicator is lit. When you no longer need this adjustment, press the AUTO TAPE TUNING button in rec pause mode or stop mode. The TAPE TUNING indicator goes out. This adjustment is also canceled when the EJECT button is pressed.

### Bias adjustment

The BIAS ADJUST control is for fine adjustment of the recording bias. If you feel that your recording needs further bias adjustment (to compensate for absent or distorted high frequencies), adjust this control to your liking.

When high frequencies are absent, boost the high frequencies.

When distortion is noticeable, attenuate the high frequencies.

BIAS ADJUST

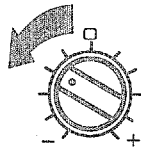

BIAS ADJUST

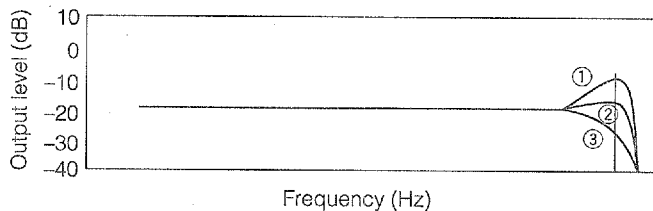
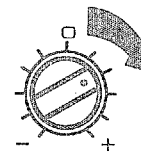

- ① Insufficient bias (Distortion is noticeable.)
- ② Optimum bias
- ③ Excessive bias (High frequencies are absent.)

### DOLBY HX PRO DYNAMIC BIAS SERVO SYSTEM

This unit incorporates the Dolby HX Pro system which automatically controls the effective bias to reduce distortion and noise, improving high frequency response during recording. Tapes recorded with this system retain the same high quality even when played back on other cassette decks.

Dolby noise reduction and HX Pro headroom extension manufactured under license from Dolby Laboratories Licensing Corporation, HX Pro originated by Bang & Olufsen.

"DOLBY", the double-D symbol  and "HX PRO" are trademarks of Dolby Laboratories Licensing Corporation.

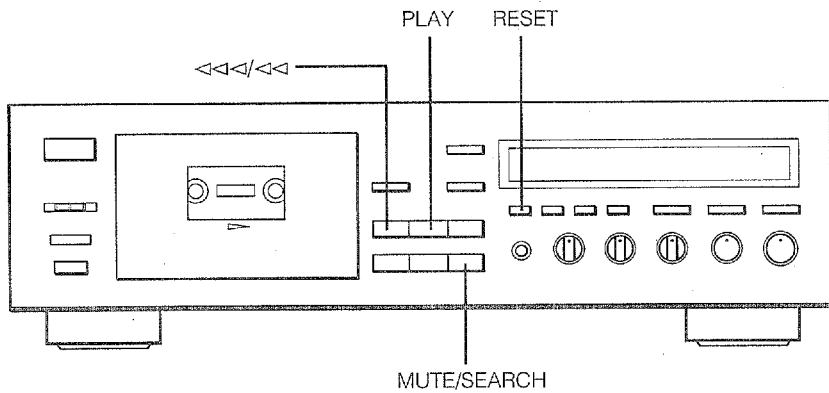

**REC MUTE OPERATION - Inserting a blank space during recording**

**0-STOP OPERATION - To return to the "0:00" point**

During recording



A 4-second blank interval is automatically recorded on the tape, and then the deck enters Rec/Pause mode. If a blank interval longer than 4 seconds is desired, keep pressing for as long as you want. When the MUTE/SEARCH button is released, the deck enters Rec/Pause mode after making a 4-second blank interval. To resume recording, press the PLAY button.

During recording

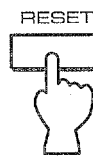

The counter reading returns to "0:00" and this point is memorized.

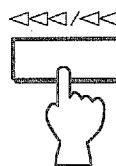

The tape will be automatically rewound to the "0:00" point and the recording mode is canceled.

**NOTE:**

The tape will stop at the point slightly ahead of the "0:00" point (around - 0:01).

**REC RETURN OPERATION - To return to the point at which the recording previously started**

During recording

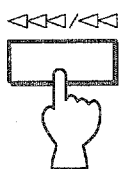

- If the PLAY button is pressed during recording, Rec return operation automatically rewinds the tape to the point where the PLAY button was previously pressed.

## TIMER RECORDING/PLAYBACK

ENGLISH

With a commercially available audio timer it is possible to make recordings and initiate playback at any time automatically. Make sure that all power cord connections between the timer and amplifier/receiver are properly made.

For details, refer to the instructions of your audio timer. No change in any of the other connections between the deck and amplifier/receiver, etc., is necessary.

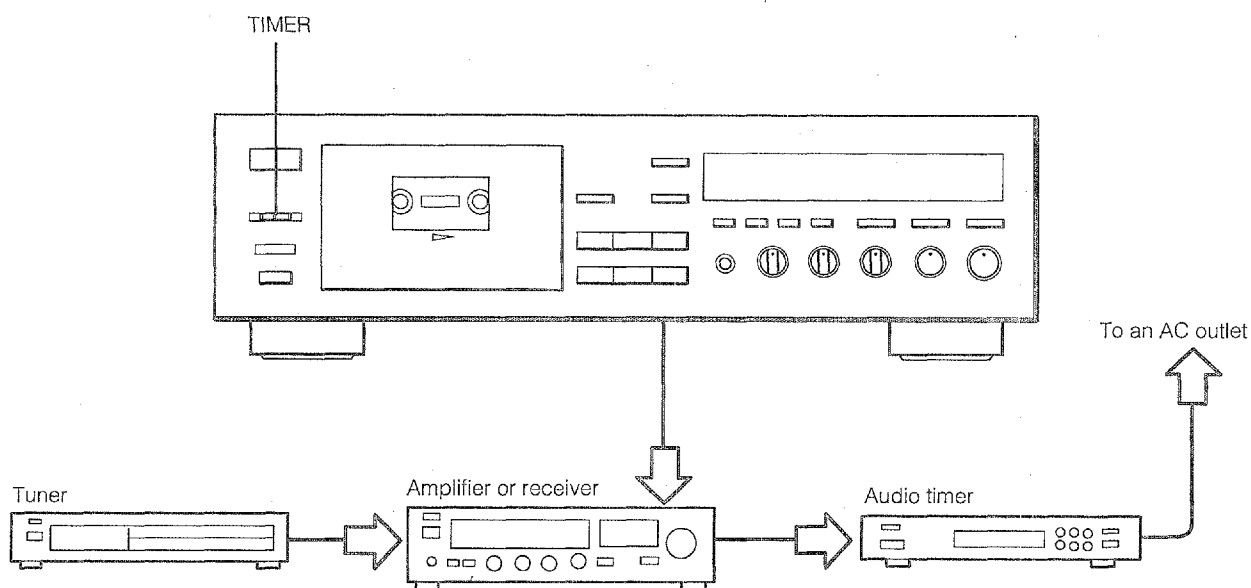

### Timer recording

1. After turning on the power to each component, select the station on your tuner which you want to record and turn down the volume on your amplifier/receiver. This will have no effect on the recording signal level. Remember to set the proper recording level.
2. Set the timer to the desired times. It is advisable to set the timer to begin recording slightly before the actual recording time and end slightly after the actual recording time, so that you leave some room for later editing.
3. Set the TIMER switch to the REC position.

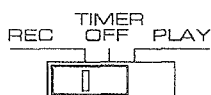

4. The timer will send power to the amplifier/receiver, tuner, and deck at the preset time, turning all the components on and initiating the recording mode.

### Timer playback

1. Turn on the amplifier/receiver and adjust the volume and tone controls.
2. Set the input mode selector of your amplifier/receiver to the cassette deck function mode.
3. Set the timer to the time you wish to start and stop playback.
4. Set the TIMER switch to the PLAY position.

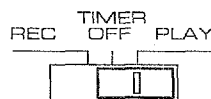

5. At the preset time, the timer will turn power on to the amplifier/receiver and cassette deck and begin playback. It will shut power off at the preset time as well ending playback.

### Notes:

- Be sure to set the TIMER switch to the OFF position when not using the timer features. Otherwise, if the power is turned on with a cassette loaded in the deck, recording or playback will start. Be especially careful to set this switch to the OFF position after timer recording to prevent erasing the recorded contents.

- If the cassette tape cannot be ejected after timer recording/playback, press the POWER button to turn on the power and then the STOP button. The EJECT button can now be operated.

## CASSETTE TAPES

### CASSETTE TAPES

There are many different types of cassette tapes available. However, they all conform to standard specifications so any brand may be used with the deck.

- Classification of Cassette Tapes by Formulation  
Cassette tapes are available in four basic types depending on their formulation, or type of magnetic material and manufacturing process. These four types are commonly known as Normal (Type I/NORM), Chrome (Type II/HIGH <math>\langle\text{CrO}\_2\rangle</math>), Ferrichrome (Type III/FeCr), and Metal (Type IV/METAL), and they each require specific tape deck adjustments for optimum performance.
- \* YAMAHA does not recommend the use of 120 minute length cassettes since the extreme thinness of the tape makes them susceptible to mechanical and recording problems.

### AUTO TAPE SELECTOR DETECTION SLOTS

The deck has a built-in Auto Tape Selector which automatically adjusts for the proper bias, level and equalization according to the tape formulation — all you have to do is load a cassette and the Auto Tape Selector does the rest.

The Auto Tape Selector determines what type of tape is loaded by sensing detector slots in the top of the tape shell. Each tape formulation has its own characteristic hole markings standardized by the tape industry.

- Early model Metal (Type IV/Metal) tape formulation cassette shells do not have the slots for Auto Tape Selector operation. As a result, early model Metal type tapes recorded on another deck will be played back with the deck at the Chrome (Type II/HIGH <math>\langle\text{CrO}\_2\rangle</math>) settings. YAMAHA does not recommend recording with this kind of tape.
- The deck does not have the required setting for Ferrichrome (Type III/FeCr) tape, since this tape formulation is not widely used. Should you use a Ferrichrome tape, it will be recorded and played back at the Normal (Type I/NORM) settings, which will result in an unnatural high frequency emphasis. This effect may be compensated for somewhat with the auto tape tuning operation or by adjusting the BIAS ADJUST to the plus (+) direction during recording, or by using the PLAY TRIM tone control and/or the tone controls of your amplifier/receiver during playback.

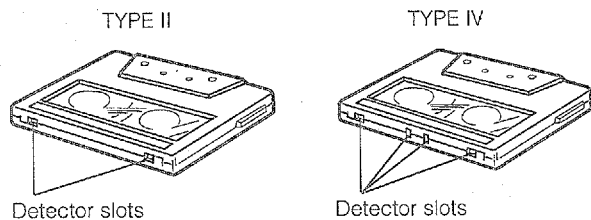

### PROTECTING YOUR RECORDINGS

All cassette tapes are provided with erasure protection holes to prevent accidental erasure of recorded contents. There is a small tab covering the hole on each side of the cassette, and it should be broken off after recording the tape. Without this tab covering the hole, it is impossible to record onto that tape. Thus, you can safely protect a recording for as long as you wish without fear of accidental erasure. Should you wish to use a cassette tape protected in this way for recording, simply covering the hole with adhesive tape will permit erasure and re-recording.

- When using Chrome (Type II/HIGH <math>\langle\text{CrO}\_2\rangle</math>) or Metal (Type IV/METAL) tapes, make sure you do not cover the hole intended for the Auto Tape Selector operation.

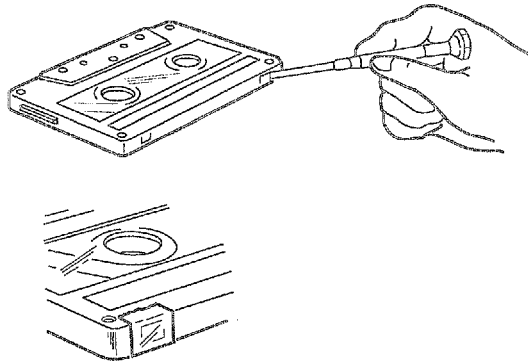

### TAKING UP SLACK IN THE TAPE

As a precaution against tape entanglement and damage, remove any slack in the tape before inserting cassettes into the deck. This is accomplished by inserting a pencil, pen or similar object into one of the spools and gently winding it until all the slack is removed. You do not have to wind it too tightly.

Be careful not to touch the tape part itself. It is very delicate and touching it may damage the tape and its recorded contents.

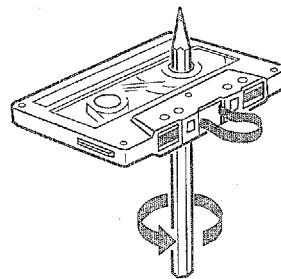

### STORING CASSETTES

After putting a cassette tape back into its case, store it in a location away from exposure to direct sunlight, humidity, high temperatures, and magnetic fields (away from television sets, speakers, etc.). High temperatures and humidity will damage the tape itself, while exposure to magnetic fields may cause a loss of recorded material. Avoid touching the tape surface with your fingers, since dirt or finger oil will contaminate the deck's heads.

## MAINTENANCE

### CLEANING OF THE TAPE PATH

Continued high quality performance of your deck is dependent upon periodic cleaning of the heads, capstan, pinch roller, and all surfaces over which the tape travels. Normal use will cause an accumulation of dirt and dust on the heads, capstans, and pinch rollers. This can lead to poor sound quality, drop outs (intervals with no sound), unsteady tape speed, loss of high frequency response, etc. Thus, clean the heads and all surfaces over which the tape travels with a commercially available cleaning cassette and fluid type cleaner.

### DEMAGNETIZATION

After 20-30 hours of use, enough residual magnetism will have built up on the heads to cause poor high frequency reproduction. At this time you should use a commercially available head demagnetizer.

- When demagnetizing the heads, be sure to follow the instructions of the head demagnetizer carefully.

Inside of the cassette compartment

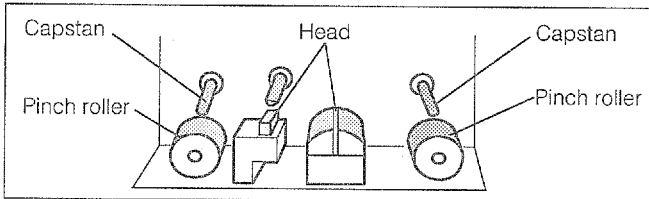

## OPTIONAL REMOTE CONTROL TRANSMITTER

With the optional remote control transmitter RS-KX1, you can operate this unit at your listening position. For details, refer to the instruction manual supplied with the remote control transmitter.

### REMOTE CONTROL OPERATION RANGE

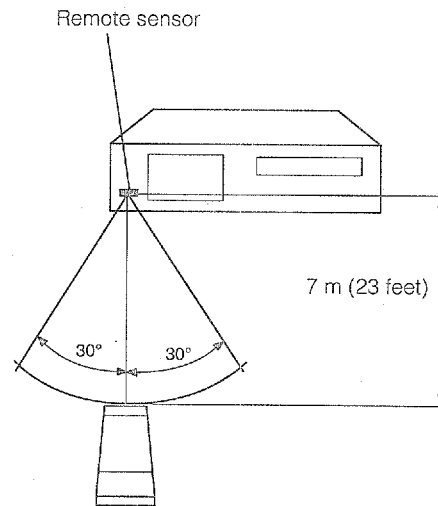
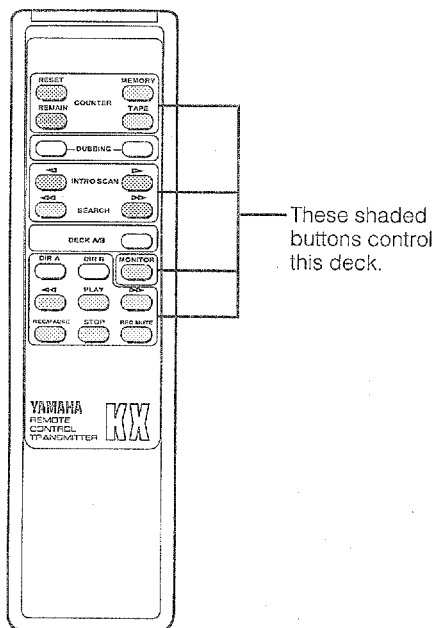



## TROUBLESHOOTING

If your cassette deck fails to operate normally, check the following table. It lists common operating errors and simple measures which you can take to correct the problem. If it cannot be corrected, or the symptom is not listed, disconnect the deck's power cord and contact your local YAMAHA dealer or service center for help.

Fault	Cause	Cure
<b>Tape doesn't move in recording or playback.</b>	<ul style="list-style-type: none"> <li>⦿ Power plug not properly plugged in.</li> <li>⦿ End of tape.</li> <li>⦿ Cassette shell is warped or damaged.</li> </ul>	<ul style="list-style-type: none"> <li>⦿ Reinsert plug properly.</li> <li>⦿ Rewind tape or flip it over.</li> <li>⦿ Do not play damaged tapes.</li> </ul>
<b>REC/PAUSE button fails to function.</b>	<ul style="list-style-type: none"> <li>⦿ No cassette tape loaded.</li> <li>⦿ Protective tabs are broken off.</li> </ul>	<ul style="list-style-type: none"> <li>⦿ Load a cassette tape.</li> <li>⦿ Change tape or cover protective hole with cellophane tape.</li> </ul>
<b>Sounds become faint and sometimes inaudible.</b>	<ul style="list-style-type: none"> <li>⦿ Head is dirty.</li> <li>⦿ Head is magnetized.</li> <li>⦿ Tape is damaged or of poor quality.</li> </ul>	<ul style="list-style-type: none"> <li>⦿ Clean head.</li> <li>⦿ Demagnetize head using head demagnetizer.</li> <li>⦿ Change to a different tape.</li> </ul>
<b>Recorded sound is distorted.</b>	<ul style="list-style-type: none"> <li>⦿ Tape is bad (stretched or deformed, etc.).</li> <li>⦿ Cassette shell is warped.</li> <li>⦿ Recording level is too high.</li> </ul>	<ul style="list-style-type: none"> <li>⦿ Replace with a fresh tape.</li> <li>⦿ A warped cassette shell cannot be fixed. Replace with another tape and test.</li> <li>⦿ Check input level with peak level meter and use lower rec level when recording.</li> </ul>
<b>Tape is playing back, but no sound is heard.</b>	<ul style="list-style-type: none"> <li>⦿ Faulty connection between deck and stereo amplifier/receiver.</li> </ul>	<ul style="list-style-type: none"> <li>⦿ Check and secure connections.</li> </ul>
<b>Excessive noise.</b>	<ul style="list-style-type: none"> <li>⦿ Head is dirty.</li> <li>⦿ Head is magnetized.</li> <li>⦿ Worn out or poor quality tape.</li> <li>⦿ Connection(s) improperly made.</li> <li>⦿ Affected by external electrical noise.</li> </ul>	<ul style="list-style-type: none"> <li>⦿ Clean head.</li> <li>⦿ Demagnetize head with head demagnetizer.</li> <li>⦿ Change to better tape.</li> <li>⦿ Check input and output connections and reinsert properly.</li> <li>⦿ Move away from electrical appliances (TV, fluorescent light, electric blanket, etc.).</li> </ul>
<b>Excessive wow (wavering of the sound).</b>	<ul style="list-style-type: none"> <li>⦿ Dirty capstan, pinch roller, etc., or poor tape.</li> <li>⦿ Tape is wound unevenly.</li> </ul>	<ul style="list-style-type: none"> <li>⦿ Clean capstan, pinch roller, or change to better tape.</li> <li>⦿ Rewind tape.</li> </ul>
<b>Tape stops in the middle of recording or playback.</b>	<ul style="list-style-type: none"> <li>⦿ Slack tape, or tape spillage wound around capstan.</li> </ul>	<ul style="list-style-type: none"> <li>⦿ Insert pencil in hole in cassette shell and turn to take up slack.</li> </ul>
<b>Fails to record.</b>	<ul style="list-style-type: none"> <li>⦿ REC LEVEL control is set too low.</li> <li>⦿ Protective tabs are broken off.</li> </ul>	<ul style="list-style-type: none"> <li>⦿ Adjust REC LEVEL control.</li> <li>⦿ Change tape or cover protective hole with cellophane tape.</li> </ul>
<b>Search does not operate.</b>	<ul style="list-style-type: none"> <li>⦿ Recorded section is too short.</li> <li>⦿ Recorded section has low-level portions.</li> <li>⦿ Conversation, etc. has been recorded.</li> </ul>	<ul style="list-style-type: none"> <li>⦿ Blank sections must be at least 4 seconds long.</li> </ul>
<b>High frequencies in the playback sound are emphasized and unpleasant to listen to, and noise level (hiss) is also high.</b>	<ul style="list-style-type: none"> <li>⦿ Dolby NR-recorded tape is played back in OFF position.</li> </ul>	<ul style="list-style-type: none"> <li>⦿ Playback in appropriate Dolby NR position.</li> </ul>

Fault	Cause	Cure
<b>Playback sound is muffled and high frequencies are inaudible.</b>	<ul style="list-style-type: none"><li>● Normally-recorded tape is played back in Dolby NR.</li><li>● Heads are dirty.</li><li>● Heads are magnetized.</li></ul>	<ul style="list-style-type: none"><li>● Playback in OFF position.</li><li>● Clean heads and carry out demagnetization with head demagnetizer.</li></ul>
<b>When playing back tapes recorded on other decks, meter deflections are greater (smaller) than when recording.</b>	<ul style="list-style-type: none"><li>● Basic levels are different for different cassette decks.</li></ul>	<ul style="list-style-type: none"><li>● This is not a fault.</li></ul>

# SPECIFICATIONS

<b>Track Configuration</b> .....	4 track, 2 channel stereo
<b>Motor</b> .....	DC servo motor (capstan) Flat torque DC motor (reel) DC motor (assist)
<b>Head</b> .....	Recording: hard permalloy Playback: hard permalloy Erase: double-gap Ferrite head
<b>Rapid Transport</b> .....	95 sec. (C-60) at high speed, 65 sec. (C-60)
<b>Wow and Flutter</b>	
<b>W.RMS</b> .....	less than 0.04%
<b>W.Peak</b> .....	less than $\pm 0.07\%$
<b>Signal-to-Noise Ratio</b>	
(Dolby NR off) .....	better than 60 dB
(Dolby B NR on) .....	better than 68 dB
(Dolby C NR on) .....	better than 76 dB
<b>Frequency Response</b>	
Normal tape (-20 dB) .....	20 ~ 18,000 Hz $\pm 3$ dB
High (CrO <sub>2</sub> ) tape (-20 dB) .....	20 ~ 19,000 Hz $\pm 3$ dB
Metal tape (-20 dB) .....	20 ~ 21,000 Hz $\pm 3$ dB
<b>Harmonic Distortion</b>	
Normal tape .....	less than 0.8%
High (CrO <sub>2</sub> ) tape .....	less than 0.8%
Metal tape .....	less than 0.8%
<b>Input Sensitivity/Impedance</b>	
Line .....	100 mV/50 k-ohms
<b>Output Level</b>	
Line .....	570 mV/2.0 k-ohms
Phones .....	1.5 mW/8 ohms
<b>Channel Separation (1 kHz)</b> .....	50 dB
<b>Cross Talk (125 Hz)</b> .....	55 dB

## GENERAL

### Power Supplies

**U.S.A. and Canada model** ..... 120 V, 60 Hz

**Europe model** ..... 230 V, 50 Hz

**U.K. model and Australia model** ..... 240 V, 50 Hz

**General model** ..... 110/120/220/240 V, 50/60 Hz

**Power Consumption** ..... 16 W

**Dimensions (W x H x D)** ..... 435 x 131 x 283 mm  
(17-1/8" x 5-3/16" x 11-1/8")

**Weight** ..... 5.2 kg (11 lbs. 7 oz.)

### Accessories

**Connecting cords** ..... 2

\* Specifications subject to change without notice.

This product complies with the radio frequency interference requirements of the Council Directive 82/499/EEC and/or 87/308/EEC.

Cet appareil est conforme aux prescriptions de la directive communautaire 87/308/CEE.

Diese Geräte entsprechen der EG-Richtlinie 82/499/EWG und/oder 87/308/EWG.

Dette apparat overholder det gældende EF-direktiv vedrørende radiostøj.

Questo apparecchio è conforme al D.M. 13 aprile 1989 (Direttiva CEE/87/308) sulla soppressione dei radiodisturbi.

Este producto está de acuerdo con los requisitos sobre interferencias de radio frecuencia fijados por el Consejo Directivo 87/308/CEE.

Dit produkt is gefabriceerd in overeenstemming met de radiostoringsvoorschriften van de Richtlijn van de Raad (82/499/EGG).

# YAMAHA

---

**YAMAHA ELECTRONICS CORPORATION, USA** 6660 ORANGETHORPE AVE., BUENA PARK, CALIF. 90620, U.S.A.  
**YAMAHA CANADA MUSIC LTD.** 135 MILNER AVE., SCARBOROUGH, ONTARIO M1S 3R1, CANADA  
**YAMAHA ELECTRONIK EUROPA G.m.b.H.** SIEMENSSTR. 22-34, D-2084 RELLINGEN BEI HAMBURG, F.R. OF GERMANY  
**YAMAHA ELECTRONIQUE FRANCE S.A.** 17 RUE DES CAMPANULES, LOGNES 77321 MARNE LA VALLEE CEDEX 2 FRANCE  
**YAMAHA ELECTRONICS (UK) LTD.** YAMAHA HOUSE, 200 RICKMANSWORTH ROAD WATFORD, HERTS WD1 7JS, ENGLAND  
**YAMAHA SCANDINAVIA A.B.** J A WETTERGRENS GATA 1, BOX 30053, 400 43 VASTRA FRÖLUNDA, SWEDEN  
**YAMAHA MUSIC AUSTRALIA PTY, LTD.** 17-33 MARKET ST., SOUTH MELBOURNE, 3205 VIC., AUSTRALIA

YAMAHA CORPORATION

VO 04340