

YAMAHA RX-330

Natural Sound Stereo Receiver
40W + 40W (8Ω) RMS Output Power, 0.04% THD, 20-20,000 Hz
16-Station Random Preset Tuning
IF Count Direct PLL Synthesizer Tuning System
Continuously Variable Loudness Control
High Dynamic Power, Low Impedance Drive Capability
CD Direct Switch
Bass Extension

Thank you for selecting the YAMAHA model RX-330 Stereo Receiver.

CENTER

OWNER'S MANUAL



CONTENTS

Safety Instructions	2
Caution	3
Supplied Accessories	7
Control Parts and Their Functions	7
Connections	9
Operations	10
Specifications	11
Troubleshooting	12

IMPORTANT!

Please make a note of the serial number of this unit in the space indicated below.

Model: **RX-330**
Serial No.:

The serial number is inscribed on the rear of the unit. Keep this Owner's Manual in a safe place for future reference.

SAFETY INSTRUCTIONS

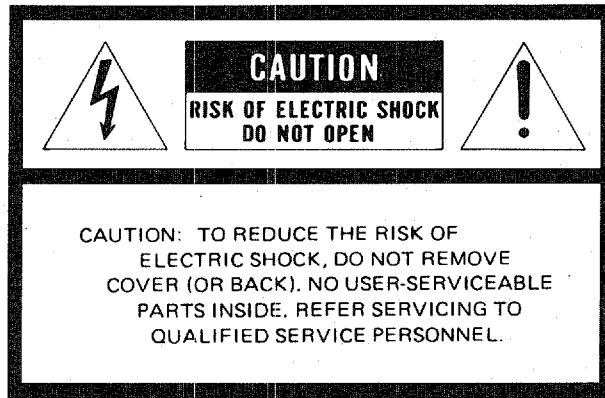

• Explanation of Graphical Symbols

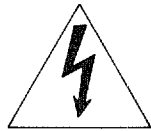

The lightning flash with arrowhead symbol, within an equilateral triangle, is intended to alert you to the presence of uninsulated "dangerous voltage" within the product's enclosure that may be of sufficient magnitude to constitute a risk of electric shock to persons.



The exclamation point within an equilateral triangle is intended to alert you to the presence of important operating and maintenance (servicing) instructions in the literature accompanying the appliance.

WARNING

To reduce the risk of fire or electric shock, do not expose this appliance to rain or moisture.

1 Read Instructions – All the safety and operating instructions should be read before the appliance is operated.

2 Retain Instructions – The safety and operating instructions should be retained for future reference.

3 Heed Warnings – All warnings on the appliance and in the operating instructions should be adhered to.

4 Follow Instructions – All operating and other instructions should be followed.

5 Water and Moisture – The appliance should not be used near water – for example, near a bathtub, washbowl, kitchen sink, laundry tub, in a wet basement, or near a swimming pool, etc.

6 Carts and Stands – The appliance should be used only with a cart or stand that is recommended by the manufacturer.

6A An appliance and cart combination should be moved with care. Quick stops, excessive force, and uneven surfaces may cause the appliance and cart combination to overturn.



7 Wall or Ceiling – The appliance should be mounted to a wall or ceiling only as recommended by the manufacturer.

8 Ventilation – The appliance should be situated so that its location or position does not interfere with its proper ventilation. For example, the appliance should not be situated on a bed, sofa, rug, or similar surface, that may block the ventilation openings; or cabinet that may impede the flow of air through the ventilation openings.

9 Heat – The appliance should be situated away from heat sources such as radiators, stoves, or other appliances that produce heat.

10 Power Sources – The appliance should be connected to a power supply only of the type described in the operating instructions or as marked on the appliance.

11 Power-Cord Protection – Power-supply cords should be routed so that they are not likely to be walked on or pinched by items placed upon or against them, paying particular attention to cords at plugs, convenience receptacles, and the point where they exit from the appliance.

12 Cleaning – The appliance should be cleaned only as recommended by the manufacturer.

13 Nonuse Periods – The power cord of the appliance should be unplugged from the outlet when left unused for a long period of time.

14 Object and Liquid Entry – Care should be taken so that objects do not fall into and liquids are not spilled into the inside of the appliance.

**CAUTION : READ THIS BEFORE
OPERATING YOUR UNIT**

15 Damage Requiring Service – The appliance should be serviced by qualified service personnel when:

- A. The power-supply cord or the plug has been damaged; or
- B. Objects have fallen, or liquid has been spilled into the appliance; or
- C. The appliance has been exposed to rain; or
- D. The appliance does not appear to operate normally or exhibits a marked change in performance; or
- E. The appliance has been dropped, or the cabinet damaged.

16 Servicing – The user should not attempt to service the appliance beyond those means described in the operating instructions. All other servicing should be referred to qualified service personnel.

17 Power Lines – An outdoor antenna should be located away from power lines.

18 Grounding or Polarization – The precautions that should be taken so that the grounding or polarization of an appliance is not defeated.

19 Outdoor Antenna Grounding – If an outside antenna is connected to the receiver, be sure the antenna system is grounded so as to provide some protection against voltage surges and built up static charges.

Section 810 of the National Electrical Code, ANSI/NFPA No. 70-1984, provides information with respect to proper grounding of the mast and supporting structure, grounding of the lead-in wire to an antenna discharge unit, size of grounding conductors, location of antenna-discharge unit, connection to grounding electrodes, and requirements for the grounding electrode.

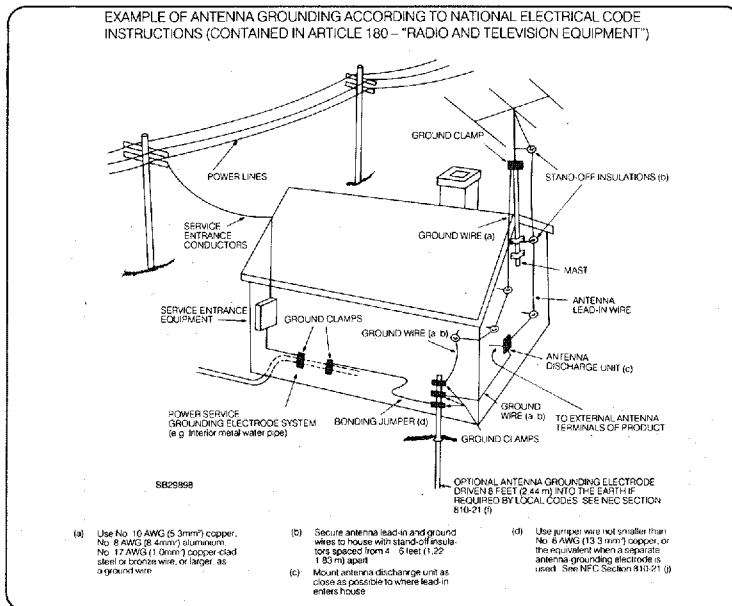

1. This unit is a sophisticated receiver. To ensure proper operation for the best possible performance, please read this manual carefully.
2. Choose the installation location of this unit carefully. Avoid placing it in direct sunlight or close to a source of heat. Also avoid locations subject to vibration and excessive dust, heat, cold or moisture. Keep it away from such sources of hum as transformers or motors.
3. Do not open the cabinet as this might result in damage to the set, or electrical shock. If a foreign object should get into the set, contact your dealer.
4. To prevent lightning damage, pull out the power cord and remove the antenna cable during an electrical storm.
5. When removing the power plug from the wall outlet, always pull directly on the plug; never pull the cord itself.
6. Do not use force when using the switches.
7. When moving the set be sure to first pull out the power plug and remove cords connected to other equipment.
8. Do not attempt to clean this unit with chemical solvent as this might damage the finish. Use a clean, dry cloth.
9. Be sure to read the "Troubleshooting" section for advice on common operating errors before concluding that this unit is faulty.
10. Keep this manual in a safe place for future reference.

1 FRONT PANEL

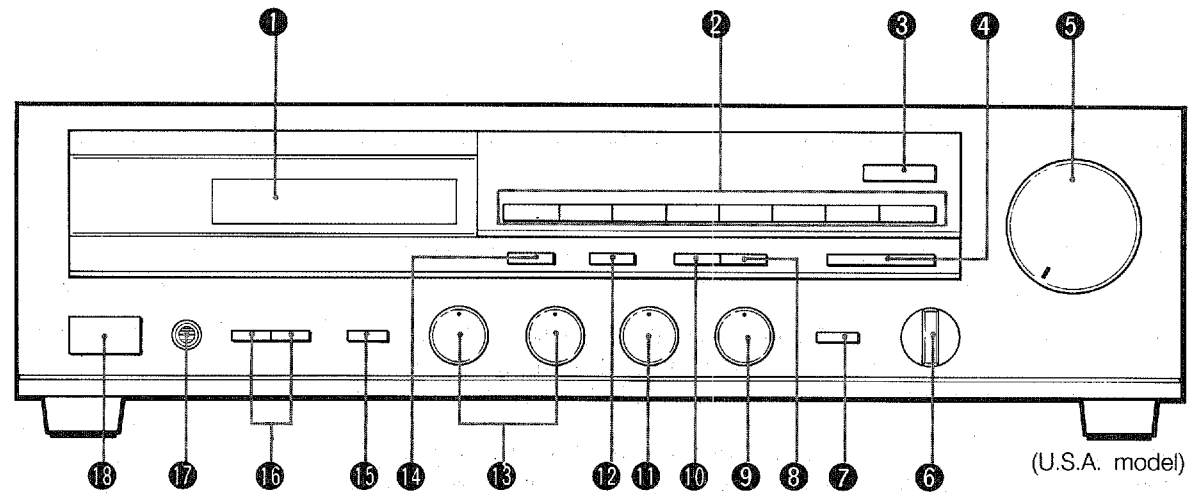

1 Display window

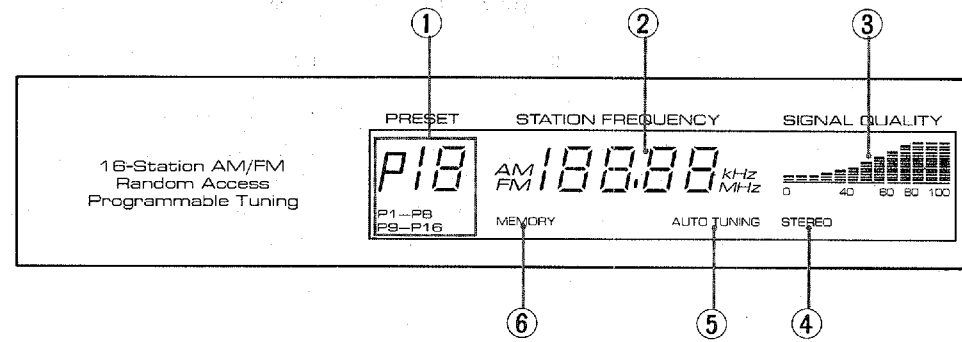

REAR PANEL

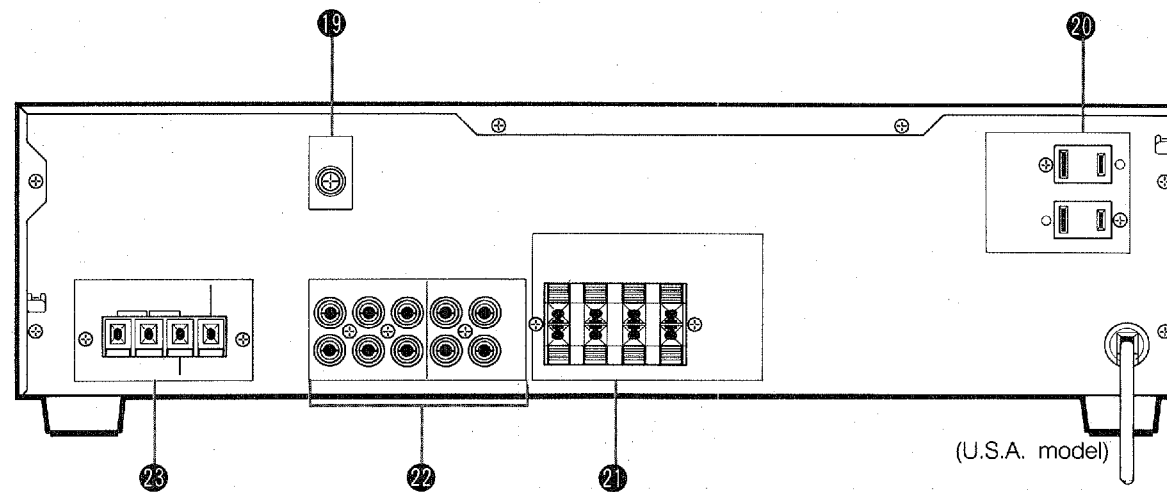

2 ANTENNA CONNECTIONS

U.S.A., CANADA, AUSTRALIA, U.K. AND GENERAL MODELS

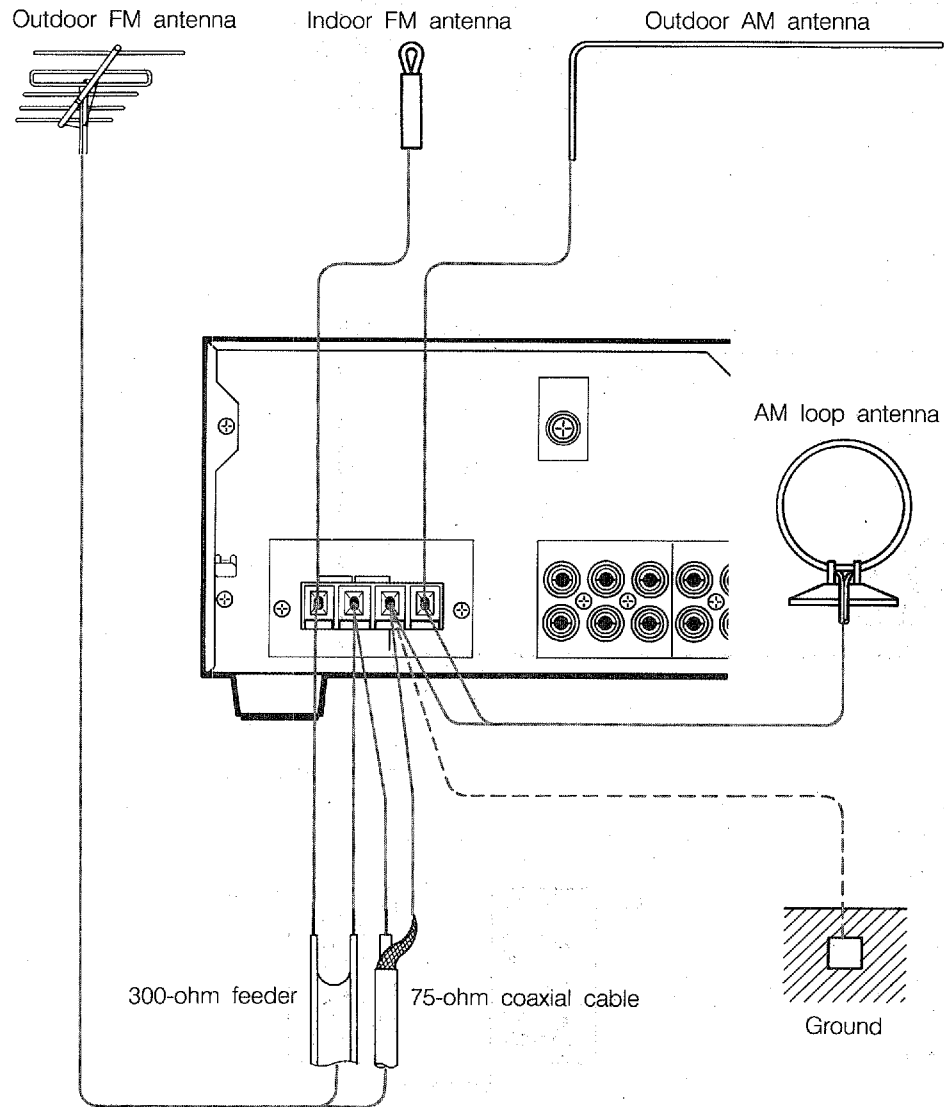

EUROPE MODEL

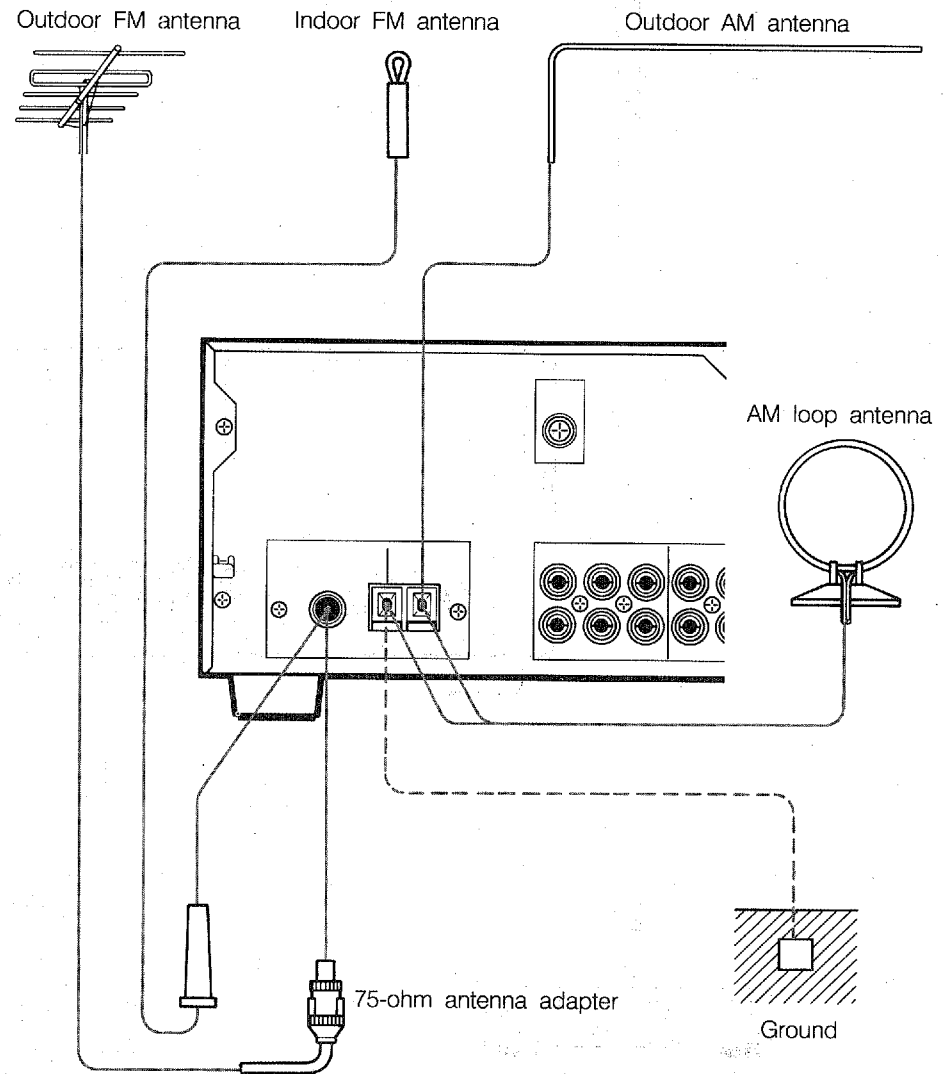

3 AUDIO CONNECTIONS

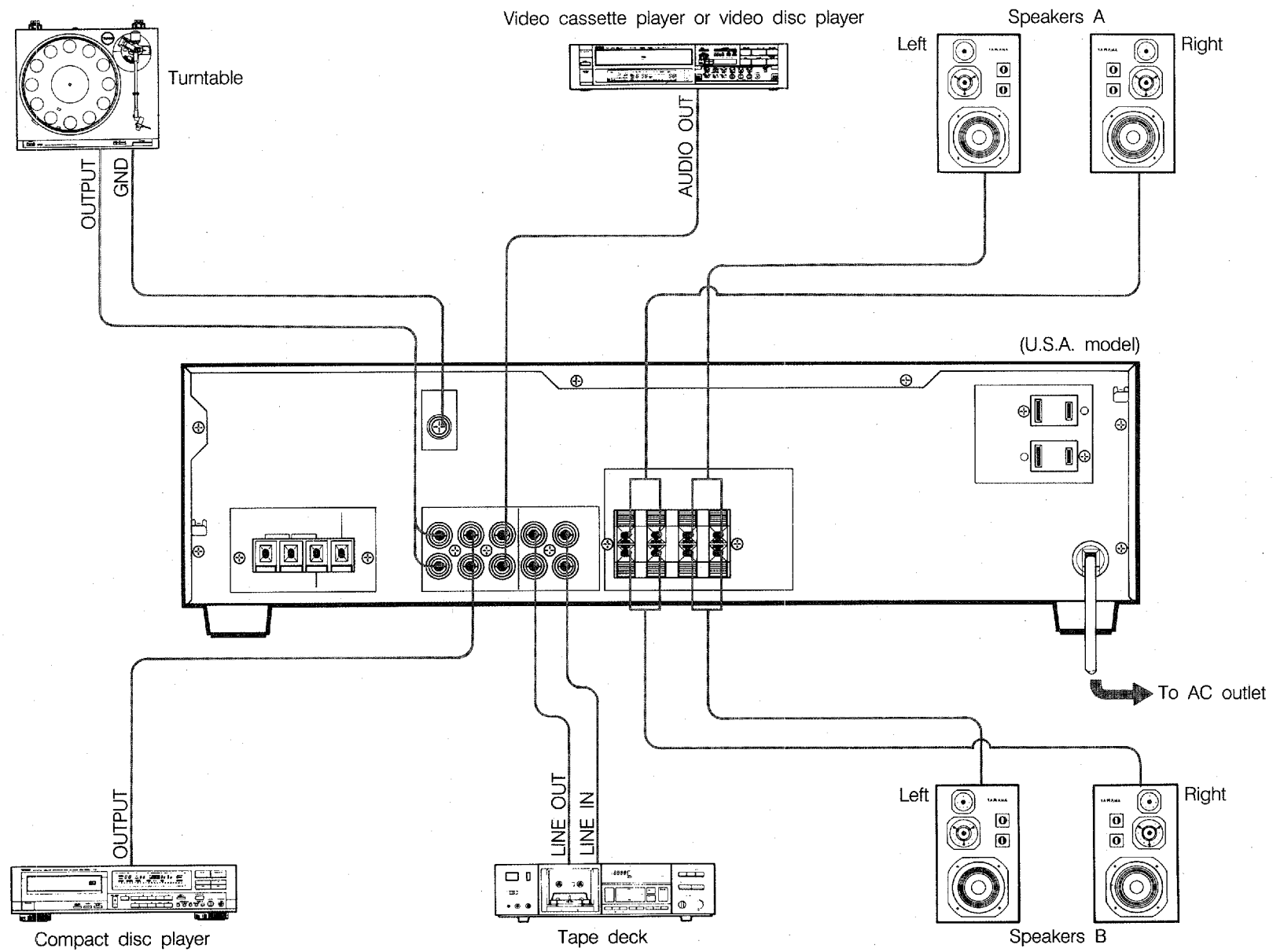

SUPPLIED ACCESSORIES

After unpacking, check that the following parts are contained.

- AM loop antenna

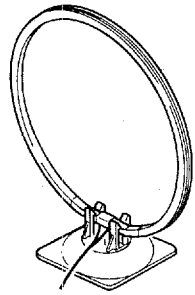

- Indoor FM antenna (Europe model)

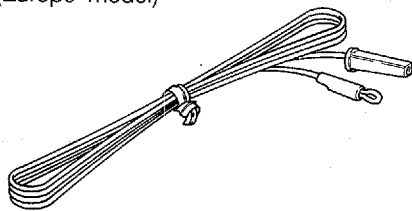

(U.S.A., Canada, Australia, U.K. and General models)

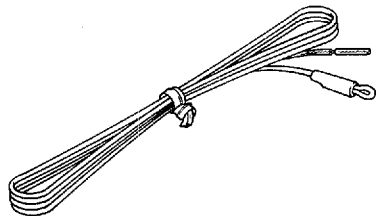

CONTROL PARTS AND THEIR FUNCTIONS

(See Fig. 1.)

FRONT PANEL

① Display window

① PRESET display

Preset station indicator

Lights up to indicate the pressed preset station button.

P1-P8/P9-P16 indicators

Indicates the range (either P1-P8 or P9-P16) of selectable preset station buttons.

② STATION FREQUENCY display

Displays the band and frequency of the received radio signal.

③ SIGNAL QUALITY indicators

These indicators display the signal strength of the tuned frequency in bar-graph form. 0 marks a poor or no signal, while 100 indicates an excellent signal.

④ STEREO indicator

When an FM stereo signal of sufficient strength is received the STEREO indicator lights up.

⑤ AUTO TUNING indicator

When the tuner is in automatic tuning mode, the AUTO TUNING indicator lights.

⑥ MEMORY indicator

When the MEMORY button is pressed, the MEMORY indicator blinks on and off.

② Preset station buttons

Up to 16 station frequencies and reception modes can be stored using the preset station button.

③ CD DIRECT switch (CD DIRECT)

This switch allows you to route the CD input signal directly to the output stage bypassing the INPUT selector, LOUDNESS, and BALANCE controls therefore avoiding any "muddying" caused by the switch and circuit routing to provide a pure sound.

④ TUNING button

Press either side of the TUNING button to carry out auto or manual tuning.

⑤ VOLUME control

This control is used to raise or lower the output volume level.

⑥ INPUT Selector

Selects the desired input source.

⑦ TAPE MONITOR button

Press this button to monitor the sound from a tape deck connected to the TAPE PB jacks on the rear panel.

⑧ TUNING MODE button

Used to select the tuning mode between AUTO and MAN'L FM MONO. In the MAN'L FM MONO mode, an FM stereo broadcasting is received in monaural.

⑨ Continuous variable LOUDNESS control

This control allows you to retain full tonal range at any volume levels. Your ear loses sensitivity to high and low frequency ranges at low volume settings. This control provides an equalization curve based on human hearing.

To adjust the LOUDNESS control to your listening level, first, set the control to the FLAT position, increase the VOLUME control to your loudest listening level, then turn the LOUDNESS control counterclockwise to reduce the volume level.

10 FM/AM button

Press this button to select the reception band between FM and AM.

11 BALANCE control

Use this control to concurrently change the left and right output volume to the speaker terminals to compensate for sound imbalance caused from speaker settings or listening room condition.

12 MEMORY button

When this button is pressed, the MEMORY indicator flickers in the display for about 5 seconds. During this period, press the desired preset station button to store the displayed frequency.

13 Tone controls

BASS

Used to increase or decrease the low frequency response. The DEFEAT position produces flat response.

TREBLE

Used to increase or decrease the high frequency response. The DEFEAT position produces flat response.

14 P1-P8/P9-P16 button

Press this button to change the range of preset station buttons. When this button is pressed, the selected range of the P1-P8/P9-P16 indicators flickers for about 5 seconds.

15 BASS EXTENSION Switch

Pressing this switch boosts bass response while maintaining overall tonal balance. This is useful to compensate for speakers with weak bass or a listening environment that deadens the bass.

16 SPEAKERS selectors

Set this selector to select the speakers to be driven.

17 PHONES jack

Plug in the headphones to this jack. To shut off the sound from the speakers, set the SPEAKERS selectors to OFF.

18 POWER switch

Press this switch to turn the power on. Press the switch again to turn the power off.

REAR PANEL

19 GND terminal

Connect the ground wire of a turntable.

20 AC OUTLETS

(U.S.A., Canada and General models)

Use these to connect the power cords from your components to the receiver.

The power to the SWITCHED outlets is controlled by the receiver's POWER switch or remote control transmitter's POWER key. They will supply power to any component whenever this unit is turned on.

The power to the UNSWITCHED outlet is not controlled by the receiver. It will continually supply power to any unit connected.

The maximum power that can be connected to the SWITCHED AC OUTLET is 100 watts and to the UNSWITCHED AC OUTLET is 200 watts.

21 SPEAKERS terminals

Two pairs of speakers A and B can be connected to these terminals.

22 Audio signal connection jacks

Use these to connect the audio signal cords from your components to the receiver. They should be connected to the proper input/output jacks for each unit. Be sure that L and R channels are connected consistently.

TAPE

Connect an audio signal of a tape deck for both recording and playback.

VIDEO/AUX

These jacks can be used to make connections from a video cassette player or video disc player. These jacks can also be used as auxiliary input jacks for other equipment.

CD

Connect a compact disc player.

PHONO

Connect a turntable.

23 Antenna terminals

Connect an FM and AM antennas to these terminals.

CONNECTIONS

NOTE ON CONNECTIONS

- Be sure to turn off the power to all units before making any connections.

ANTENNA CONNECTIONS

(See Fig. 2.)

• AM loop antenna

Connect the AM loop antenna cords to the AM ANT and GND terminals.

- ① Depress the tabs of AM ANT terminals.
- ② Connect the AM loop antenna leads to the AM ANT terminals.
- ③ Release the tabs. Lightly pull on the leads to confirm a good connection.

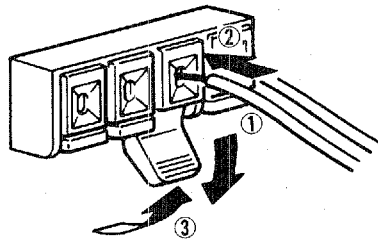

- ④ Attach the loop antenna to the antenna stand.

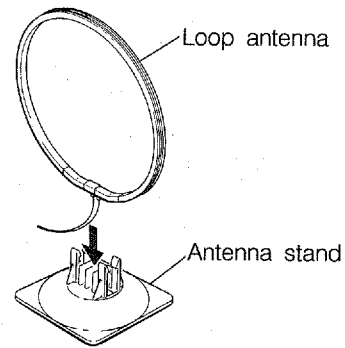

- ⑤ Orient the AM loop antenna so that the best reception is obtained.

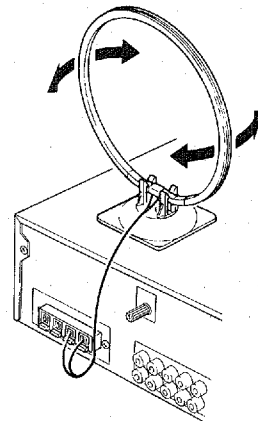

* The antenna may be hung on a wall.

• Outdoor AM antenna

The end of the wire should be stripped of insulation and connected to the AM ANT terminal. At this time, keep the loop antenna connected.

• Supplied indoor FM antenna

(U.S.A., Canada, Australia, U.K. and General models)
Connect the supplied indoor antenna to either of the 300 Ω BAL. FM ANT terminals. Move the antenna for best reception.

(Europe Model)

Connect the supplied indoor antenna to the 75 Ω UNBAL. FM ANT terminal.

- * Insert so that the grooved part of the connector hole is facing downward when the connection is made.

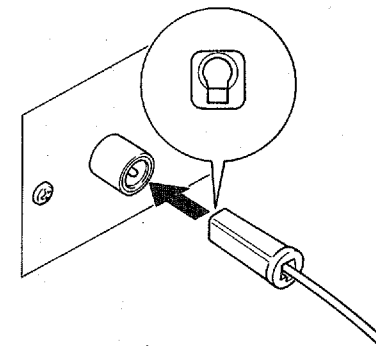

• Outdoor FM antenna

If necessary an outdoor FM antenna may be used for improved FM reception. Either 300-ohm feeder or coaxial cable may be used. In locations troubled by electrical interference, coaxial cable is preferable.

FREQUENCY STEP switch

(General model only)

As the interstation frequency spacing differs in different areas, set the FREQUENCY STEP switch located at the rear according to the frequency spacing in your area.

OPERATIONS

AUDIO CONNECTIONS

(See Fig. 3.)

- **Power cord**

Connect the power cord of your receiver to an AC outlet.

- **Speakers**

Connect the SPEAKERS terminals to your speakers with the proper gauge of wire, cut to be as short as possible. Press the speaker wire terminal tabs down, then insert the bare wires and secure them by releasing the tabs. If these connections are faulty, no sound will be heard from the speakers. Make sure that the polarity of the speaker wires is correct, that is, that the + and - markings are observed. If these wires are reversed, the sound will be unnatural and will lack bass. Do not coil up excess speaker wire or bundle the speaker cables with the power cords.

- **Turntable**

Connect the output cords of the turntable to the PHONO jacks, and connect the ground cord to the GND terminal. This should produce minimum hum, but in some cases better results are obtained with this cord disconnected.

- **Compact disc player**

Connect the output jacks of the compact disc player to the CD jacks.

- **Video cassette player etc.**

Connect the audio output jacks from a video cassette player, a CDV player or a video disc player to the VIDEO/AUX jacks.

- **Tape deck**

Connect the cords from a cassette deck to the TAPE jacks. The playback (LINE OUT) jacks go to the TAPE PB jacks, and the record (LINE IN) jacks go to the REC OUT jacks.

TO LISTEN TO RADIO PROGRAM

Auto Tuning

If signals are strong and there is no interference, quick automatic search tuning is possible.

1. Select the reception band with FM/AM button.
2. Press the TUNING MODE button so that the AUTO TUNING indicator lights up.
3. Use the TUNING button to tune.
The tuning will start automatically and stop at broadcast station frequency with a sufficient signal strength.
4. If the station where tuning stops is not the one you want, press the TUNING button once again.

Manual Tuning

Auto tuning may be impossible if the station signal is weak. If so, use manual tuning.

1. Select the reception band with FM/AM button.
2. Press the TUNING MODE button so that the AUTO TUNING indicator goes off.
3. Use the TUNING button to tune.
The frequency will change rapidly if the TUNING button is kept pressed. Release it slightly before reaching the desired frequency, and then press it intermittently until the desired frequency is reached.

Preset Tuning

The preset station button can be used to select, at a single touch, any desired station which has been preset.

1. Tune to the desired station using auto or manual tuning mode.
2. Select the range of the preset station button with the P1-P8/P9-P16 button.

3. Press the MEMORY button and then while the MEMORY indicator is flickering, press the desired preset station button.
 4. To receive the preset station, select the range of the preset station with the P1-P8/P9-P16 button and press the desired preset station button.
- Follow the same procedure for other preset station buttons.
The new setting will be programmed in place of the former one.

Memory back-up

The memory back-up circuit will prevent the programmed information from being lost even though the power is switched OFF for timer use or other temporary power failure. If, however, the unit is not used for a long time, the memory may be erased. If so, it can be re-programmed by simply following the original procedure.

TO PLAY PROGRAM SOURCE

1. Select the program source to be heard with the input selector.
2. Play the program source.
3. Adjust the VOLUME and tone controls.

TO RECORD ON TAPES

1. Use the Input selector to select the source to be recorded.
2. Activate the source component then turn the volume up to confirm the input source.
3. Set the tape deck to RECORD.
If your tape deck has three head monitoring capability you can monitor the just recorded signal by setting the TAPE MONITOR button to TAPE.
4. Adjusting VOLUME, LOUDNESS, BASS, TREBLE and BALANCE controls during recording has no effect on the material being recorded.

SPECIFICATIONS

AUDIO SECTION

Minimum RMS Output Power per Channel	
8 ohms, 20 Hz to 20 kHz, 0.04% THD	
[U.S.A., Canada and General models]	40 W
[Australia, Europe and U.K. models]	35 W
6 ohms, 20 Hz to 20 kHz, 0.06% THD	
[U.S.A., Canada and General models]	42 W
[Australia, Europe and U.K. models]	40 W
Dynamic Power per Channel (IHF)	
8/6/4/2 ohms	
[U.S.A., Canada and General models]	67/78/95/88 W
[Australia, Europe and U.K. models]	60/70/80/82 W
DIN Standard Output Power per Channel	
4 ohms, 1 kHz, 1% THD	
[Europe model only]	47 W
IEC Power (1 kHz, 0.04% THD, 8/6 ohms)	
[Europe model only]	45/48 W
Power Band Width	
8 ohms, 20 W, 0.1% THD	10 Hz to 40 kHz
Damping Factor	
8 ohms, 1 kHz	50 or more
Input Sensitivity/Impedance	
PHONO	2.5 mV/47 k-ohms
CD/TAPE/VIDEO/AUX	150 mV/50 k-ohms
Maximum Input Signal Level (1 kHz, 0.01% THD)	
PHONO	120 mV
Output Level/Impedance	
REC OUT	150 mV/100 ohms
Headphone Jack Rated Output/Impedance	0.55 V/ 8 ohms
Frequency Response (20 Hz to 20 kHz)	
CD/TAPE/VIDEO/AUX	±0.5 dB
RIAA Equalization Deviation (20 Hz to 20 kHz)	
PHONO	±0.5 dB
Total Harmonic Distortion (20 Hz to 20 kHz)	
PHONO to REC OUT (3 V)	0.01%
CD/TAPE/VIDEO/AUX to SP OUT (20 W/8 ohms)	0.02%
Intermodulation Distortion	
CD/TAPE/VIDEO/AUX (Rated Output/8 ohms)	0.04%
Signal-to-Noise Ratio (IHF-A Network)	
PHONO (5 mV Input Shorted)	
[U.S.A., Canada and General models]	88 dB
[Australia, Europe and U.K. models]	82 dB
CD/TAPE/VIDEO/AUX (Shorted)	103 dB
Residual Noise (IHF-A Network)	140 µV
Channel Separation (1 kHz, Vol. -30 dB)	
PHONO (Input Shorted)	55 dB
CD/TAPE/VIDEO/AUX	
(Input 5.1 k-ohms Terminated)	52 dB

Tone Control Characteristics

BASS : Boost/cut	±10 dB (50 Hz)
Turnover Frequency	350 Hz
TREBLE : Boost/cut	±10 dB (20 kHz)
Turnover Frequency	3.5 kHz
Filter Characteristics	
Bass Extension	60 Hz, 8 dB/oct
Continuous Loudness Control	-40 dB (1 kHz)
	(Level related equalization)

FM SECTION

Tuning Range	
[U.S.A., Canada and General models]	87.5 to 107.9 MHz
[Australia, Europe, U.K. and General models]	87.5 to 108.0 MHz
50 dB Quietening Sensitivity (IHF, 75 ohms)	
[Except Europe model]	
Mono	1.55 µV (15.1 dBf)
Stereo	21 µV (37.7 dBf)
Usable Sensitivity (75 ohms)	
(30 dB S/N Quietening, 1 kHz, 100% mod.)	
[Except Europe model]	0.8 µV (9.3 dBf)
DIN, Mono (S/N 26 dB) [Europe model]	1.4 µV
DIN, Stereo (S/N 46 dB) [Europe model]	30 µV
Image Response Ratio	
[Except Europe model]	45 dB
[Europe model]	80 dB
IF Response Ratio	80 dB
Spurious Response Ratio	70 dB
AM Suppression Ratio	55 dB
Capture Ratio	1.5 dB
Alternate Channel Selectivity	
[Except Europe model]	85 dB
Selectivity (two signals, 40 kHz Dev.)	
[Europe model]	50 dB
Signal-to-Noise Ratio	
(IHF) Mono/Stereo	
[Except Europe model]	81/76 dB
(DIN-weighted, 40 kHz Dev.) Mono/Stereo	
[Europe model]	75/70 dB
Harmonic Distortion (1 kHz)	
Mono/Stereo	
[Except Europe model]	0.1/0.2%
Stereo (40 kHz Dev.)	
[Europe model]	0.2%
Frequency Response	
30 Hz to 15 kHz	0 ±0.5 dB

Stereo Separation (1 kHz)

[Except Europe model]	50 dB
[Europe model (40 kHz Dev.)]	50 dB

AM SECTION

Tuning Range	
[U.S.A., Canada and General models]	530 to 1,610 kHz
[Australia, Europe, U.K. and General models]	531 to 1,611 kHz
Usable Sensitivity	250 µV/m
Selectivity	32 dB
Signal-to-Noise Ratio	50 dB
Image Response Ratio	40 dB
Spurious Response Ratio	50 dB
Harmonic Distortion (400 Hz)	0.3%

AUDIO SECTION

Output Level/Impedance	
FM (30% mod., 1 kHz)	
[Except Europe model]	150 mV/2.2 k-ohms
[Europe model (40 kHz Dev.)]	400 mV/6.8 k-ohms
AM (30% mod., 400 Hz)	
[Except Europe model]	150 mV/2.2 k-ohms
[Europe model (40 kHz Dev.)]	150 mV/6.8 k-ohms

GENERAL

Power Supply	
[U.S.A. and Canada models]	AC 120 V, 60 Hz
[Australia and U.K. models]	AC 240 V, 50 Hz
[Europe model]	AC 220 V, 50 Hz
[General model]	AC 110-120/220-240 V, 60/50 Hz
Power Consumption	
[U.S.A., Canada and General models]	145 W
[Australia, Europe and U.K. models]	260 W
AC Outlets	
[U.S.A., Canada and General models only]	
Switched	100 W max.
Unswitched	200 W max.
Dimensions (W x H x D)	435 x 126 x 290.7 mm
	(17-1/8" x 4-15/16" x 11-7/16")
Weight	5.2 kg (11 lbs. 7 oz.)
Accessories	AM loop antenna x 1
	Indoor FM antenna x 1

Specifications subject to change without notice.

TROUBLESHOOTING

If the unit fails to operate normally, check the following points to determine whether the fault can be corrected by the simple measures suggested. If it cannot be corrected, or if the fault is not listed in the SYMPTOM column, disconnect the power cord and contact your dealer or service center for help.

	SYMPTOM	CAUSE	REMEDY
Amplifier	The receiver fails to turn on when the POWER switch is pressed.	Power cord is not plugged in or is not completely inserted.	Firmly plug in the power cord.
	No sound.	Incorrect output cord connections.	Connect cord properly. If the problem persists, the cables may be defective.
		Incorrect receiver operation.	Set the receiver controls to the correct input selection.
	Sound "hums".	Incorrect cord connections.	Firmly connect the audio plugs. If the problem persists, the cord may be defective.
FM	FM stereo reception is noisy.	Because of the characteristics of FM stereo broadcasts, this is limited to cases where the transmitter is far away or the antenna input is poor.	Check the antenna connections. Try using a multiple element FM antenna.
	There is distortion and clear reception cannot be obtained even with a good FM antenna.	There is multipath interference.	Adjust antenna placement to eliminate multipath interference.
	A desired station cannot be tuned in with Auto tuning.	The station is too weak.	Use Manual tuning mode. Use high quality directional FM antenna.
AM	A desired station cannot be tuned in with Auto tuning.	Weak signal or loose antenna connections.	Tighten the AM loop antenna connections and rotate it for best reception. Use Manual tuning mode.
	There are continuous crackling and hissing noises.	These noise result from lightning, fluorescent lamps, motors, thermostats and other electrical equipment.	Use an outdoor antenna and a ground wire. This will help some what but it is difficult to eliminate all noise.
	There are buzzing and whining noises (especially in the evening).	A television set is being used nearby.	Move the television away.

YAMAHA

YAMAHA CORPORATION
 10-1, Nakazawa-cho, Hamamatsu, 430 Japan
 Bwgg, BB   Printed in Japan