



S2100 series

Compact CD Player CD-S2100
Integrated Amplifier A-S2100





Relentless Pursuit of Musicality

Audio is not just sound.

If there's music in it, that's an entirely different universe.

For audio deserving the name "Hi-Fi" the need for high-definition sound is a given, and even more than that, high expressive power is demanded.

Supreme quality sound, and dynamic expressive power are things we at Yamaha, as a premier musical instrument maker, have always pursued. This is the rich musicality of listening enjoyment.

High-grade Hi-Fi components. The S2100 Series.

An airy, open sound in which the most minute sounds reach the listener.

Expressive power that conveys even the subtlest nuances which the artist pours into the music.

A realistic sensation that you are directly in front of the performer. These are the goals and overriding philosophy behind the sound and sophisticated technologies inherited from the flagship S3000 Series.

Emotional & Dynamic. The sound created by the S2100 Series, reverberating vibrantly in the ears, and reverberating vibrantly in your ears, and resonating in your heart.



Powered by music



The abundance in the music

Put your favourite disk in the player and soak in the melody that flows your way.

Do you get an uplifting feeling from it?

Does it stir your emotions? Does it offer you profound consolation?

Introducing the S2100 Series—beautiful and elegant in appearance,
powerful and graceful in reproducing music for your ultimate enjoyment.

The time you spend with its sound is something irreplaceable.

It's a moment when you can, through music, be on the same wavelength as the artist.

To all those who love music, the S2100 Series brings warm emotions and a feeling of abundance,
from listening to music in truly superior sound.



A-S2100

Integrated Amplifier

NEW PRODUCT BULLETIN

Advanced original amplifier circuitry and elimination of signal loss—resulting in a truly emotional and dynamic sound. This is a high-grade integrated amplifier that has inherited the new sound of Yamaha in the pursuit of rich musicality.

The S2100 Series was born from the goal to deliver new Hi-Fi components with superior musicality—components which can be created only by the world's premier musical instrument manufacturer, Yamaha. The A-S2100 integrated amplifier inherits the world-class original amplifier circuit from Yamaha's flagship model in order to create excellent quality bass, an indispensable element in achieving sound rich in musicality. It has realised preeminent drive capacity, allowing you to experience the dynamism and even the emotion in the music. It also has beautiful level meters that let you visually enjoy your music. We sought—and succeeded—to bring you the ideal amplifier, so you can be filled with all the joy that music possesses.

- Yamaha's own unique Floating and Balanced Power Amplifier, utilising MOSFETs, delivers powerful, highly dynamic sound filled with energy.
- All-stage balanced transmission and low impedance, plus fully discrete amp construction reduce noise and eliminate signal transmission loss.
- With its elegant design and beautiful level meters, the A-S2100 expresses in every way the lively dynamism of music, and the joy inside.

Floating and Balanced Power Amplifier with MOSFETs

The basic design of the power amp circuit adopts Yamaha's own, uniquely developed Floating and Balanced Power Amplifier technology. Adopting output elements with the same polarity on the plus and minus sides of the output stage, and also completely separating the NFB (Negative Feedback) circuit and power supply into total of four plus and minus sides of the left and right channels, results in thoroughly symmetric push-pull operation of the output stage,

Completely floating the entire power amp circuit from the ground removes any negative impact of minute voltage fluctuations or ground noise. Moreover, the output elements are comprised of



MOSFETs, which provide a warm and natural sonic character. The use of MOSFETs, which have the same polarity on the plus and minus sides, further evolves the ideal of a complete symmetrical design, to eliminate sound quality variations due to difference in polarity—a major distinguishing characteristic of the Floating and Balanced Power Amplifier—resulting in sound with a superior signal-to-noise ratio and superbly well-defined sound field.



A-S2100 Floating and Balanced Power Amplifier

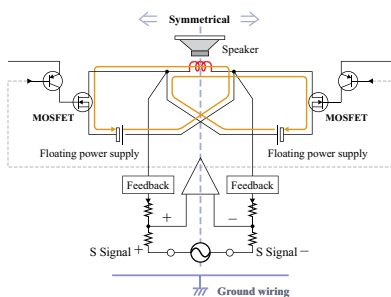

All-stage fully discrete construction, balanced transmission and low impedance design

The A-S2100 has achieved a fully discrete configuration during tone defeat, by thoroughly separating the tone control circuit from the signal system. This not only

increases response but also improves slew-rate, and results in high range reproduction of greater vitality, richness and smoothness. Signal transmission and amplification features fully balanced transmission for thoroughly balanced operation, even

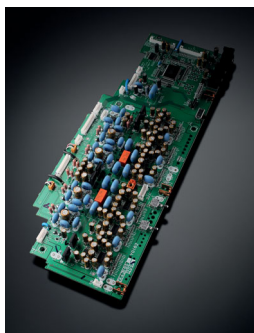

of the control system circuitry. Signal loss through transmission has been significantly reduced, with the application of screw clamp connections and thick cables in connecting the pre amp unit with the power amp unit, which is vital for signal transmission, and in connecting the power step to the speaker terminals. This improves the damping factor and improves driver capacity and damping power of the speaker, resulting in vibrant and powerful bass reproduction.

A-S2100 Balanced Circuit Design

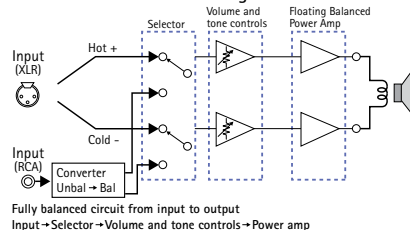

Fully balanced circuit from input to output
Input → Selector → Volume and tone controls → Power amp

Superior quality electronic volume control for optimum sound

We've utilised a high-quality digital volume control specially designed by New Japan Radio Co., Ltd., which consists only of ladder-type resistance, removing the impact of slew-rate decline or colouring of the sound, delivering higher purity in the sound, and excellent, fast response to large volume changes and

step transients. Moreover, the tone controls employ a triple-parallel method, minimising the detrimental impact on sound quality seen with straight-line tone controls. In addition, the bass, treble, and common circuits each utilise simple construction in which the NFB of the amp is not used and the CR elements are simply fixed in a straight line, ensuring exceptionally pure sound reproduction even when tone control is applied and superb response to audio signal transients. When tone defeat is applied, straight signal flow from only one volume circuit to a discrete configuration buffer amp is realised.

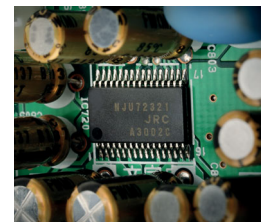

Triple-parallel tone control system signal flow

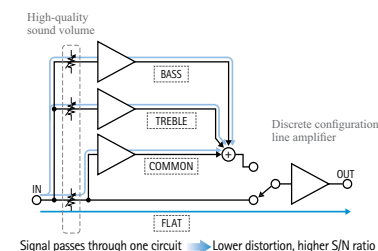

Large capacity power supply unit delivers energetic, dynamic sound with fast response

The A-S2100 employs an original EI transformer, carefully customised for optimum compatibility with the chassis. Combining four large capacity carbon sheath block capacitors delivers an energetic sound—even during high volume—that is possible only with the A-S2100. Moreover, since the control amp and control system is equipped with twelve shunt type local regulators that prevent deterioration caused by currency fluctuation, a clean and stable power supply is achieved. The EI transformer is mounted on the chassis using brass washer, restricting internal vibration that would result in noise.



Symmetrical design in pursuit of ideal stereo reproduction

The left-right symmetrical construction with the power supply in the centre and the power amp blocks on the ends achieves greater separation of the left and right channels—necessary for proper two-channel stereo reproduction—and ideal weight balance. Including fine tuning by a centre frame which

extends from the front to the back of the casing and specially made metal legs (selectable from spike or pad), the A-S2100 has superb mechanical rigidity and installation stability that dramatically lessens the impact of external vibrations on sound quality.

Discretely configured phono amp

The phono amp is comprised of an MC head amp and an equaliser amp, each of which are discretely configured, resulting in a rich sound with pronounced musicality, when playing vinyl records with both MC and MM phone cartridges.

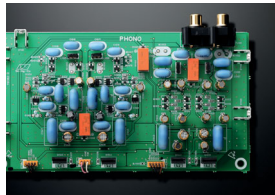

Headphone amp with fully discrete configuration

The headphone amp also is equipped with fully discrete configuration, for preeminent drivability and damping properties. Included as well is a specialised level trimmer that responds to various load impedances. The superior quality sound that only the A-S2100 can attain is yours to enjoy, even when listening on headphones.

Level meters visually reflect the dynamics in the music

The centre of the main unit features level meters that provide visual enjoyment of the music as well, with the rapid and delicate movement of the needles. The meter is illuminated softly from inside by LED, giving a warm, beautiful lamplight look. The meter indicators can, along with VU display, be switched to peak display, and can be selected according to your preferences. The window of the meters has been precision-fit to the panel—completely flat, with no gaps—for an elegantly beautiful appearance.

Elegant design with luxurious real wood panels

The refined design and construction of the A-S2100 reflects Yamaha's commitment to fine craftsmanship and art, uniquely drawing on its long experience as a world-class musical instrument maker. The metal front panel and the side wood panels have been beautifully integrated by the masterful use of advanced processing technology. Moreover, the dials and tone controls are machined aluminium knobs, for a richly textured finish and graceful touch.

Original speaker terminals combine ease of use and beauty with high sound quality

Our meticulous obsession with quality continues through to the speaker terminals, which are the last and crucial link in the audio chain. Featuring screw type terminals, with originally designed handles, these are created by cutting pure brass, enabling secure connection with no reduction in sound quality.

Contoured to the shape of human fingers, they not only look beautiful, but can be turned easily and fastened tightly with minimal effort. They are also compatible with connections using banana plugs.

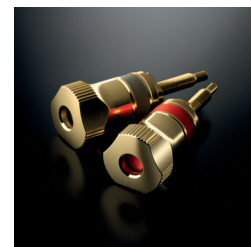

Remote control with simple design and superior texture

The supplied remote control features a design complementary to the aluminium panel of the amplifier itself, with a simple, easy-to-understand button layout and gorgeous metallic texture. In addition to the basic volume adjustment and input switching controls of the A-S2100, it can also be used for operation of the companion CD-S2100.





Silver finish (piano finish sides)



* The sides are also available in Piano Black and Natural Birch finishes.



Black finish (piano finish sides)

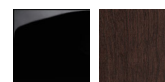

* The sides are also available in Piano Black and Dark Brown finishes.

A-S2100 Main Specifications

[AUDIO SECTION]

Maximum Power	(4 ohms, 1 kHz, 0.7% THD, for Europe)	160 W + 160 W
IEC Power	(8 ohms, 1 kHz, 0.02% THD, for Europe)	95 W + 95 W
Rated Output Power	(8 ohms, 20 Hz—20 kHz, 0.07% THD)	90 W + 90 W
	(6 ohms, 20 Hz—20 kHz, 0.07% THD)	110 W + 110 W
Maximum Power (JEITA)	(8 ohms, 1 kHz, 10% THD)	120 W + 120 W
	(4 ohms, 1 kHz, 10% THD)	190 W + 190 W
Dynamic Power/Channel	(8/6/4/2 ohms)	105 W/135 W/190 W/220 W
Damping Factor	(8 ohms, 1 kHz)	250
	CD	200 mV/47 k-ohms
Input Sensitivity/Impedance	Phono MM	2.5 mV/47 k-ohms
	Phono MC	100 μV/50 ohms
	Main In	1.0 V/47 k-ohms
	CD, etc. to Speaker Out, Flat Position	5 Hz–100 kHz +0 dB/-3 dB
Frequency Response	CD, etc. to Speaker Out, Flat Position	20 Hz–20 kHz, +0 dB/-0.3 dB
	Phono MM (20 Hz–20 kHz,)	±0.5 dB
RIAA Equalisation Deviation	Phono MC (20 Hz–20 kHz,)	±0.5 dB
	CD Balanced to Speaker Out	0.025% (50 W/8 ohms)
Total Harmonic Distortion (20 Hz–20 kHz)	CD, etc. to Speaker Out	0.025% (50 W/8 ohms)
	Phono MM to Rec Out	0.005% (1.2 V)
	Phono MC to Rec Out	0.02% (1.2 V)

Signal-to-Noise Ratio (IHF-A Network)	CD, etc. (200 mV, Input Shorted)	103 dB
	Phono MM (5 mV, Input Shorted)	93 dB
	Phono MC (500 μV, Input Shorted)	85 dB
Residual Noise	(CD, etc., IHF-A-Network)	33 μV
	CD, etc., Input 5.1 k-ohms Terminated	74 dB/54 dB
Channel Separation (1 kHz/10 kHz)	Phono MM, Input Shorted, Vol: -30dB	90 dB/77 dB
	Phono MC, Input Shorted, Vol: -30dB	66 dB/77 dB
	Bass Boost/Cut (at 50 Hz)	±9 dB
Tone Control Characteristics	Bass Turnover Frequency	350 Hz
	Treble Boost/Cut (at 20 Hz)	±9 dB
	Treble Turnover Frequency	3.5 kHz
	Audio Muting	-20 dB (approx.)

[GENERAL SECTION]

Dimensions	(W x H x D)	435 x 157 x 463 mm 17-1/8" x 6-1/8" x 18-1/4"
Weight		23.4 kg 51.6 lbs.





CD-S2100

Compact Disc Player

NEW PRODUCT BULLETIN

New circuit design for elimination of audio loss, plus high-precision drive mechanism for reproduction accuracy. This high-grade CD player delivers the new sound of Yamaha, and is equipped with high-performance USB audio and DAC, and other advanced functions.

The S2100 Series was born from the goal to deliver new Hi-Fi components with superior musicality —components which can be created only by the world's premier musical instrument manufacturer, Yamaha. The CD-S2100 CD player incorporates many high sound quality technologies such as a new circuit configuration, high-performance DAC, and other features which have been adopted for use in our flagship models, in order to extract and transmit all the audio information recorded on discs without any loss.

It also includes USB audio input and advanced DAC specifications that let you enjoy the newest music formats including high-resolution sound sources with the best sound quality.

Here is the highest level of sound quality and functionality, giving you the full experience and greatest musical enjoyment you can get from all your music contents including CDs.

In the quality of the sound, in the level of the functionality, we sought to deliver the absolute best.

- Left-right symmetrical construction and Independent configuration of digital/analogue circuits with optimisation of power supply
- Reinforcing anchors and rigid CD mechanism for high precision signal reading
- High-performance, high-resolution 32-bit DAC from ESS for an airy, open and transparent sound with all the audio data intact
- Built-in USB DAC functions are compatible with high-resolution audio sources, allowing use of the superior D/A conversion capability of the CD-S2100

Left-right symmetrical construction, independent digital/analogue circuit configuration, with top priority on sound quality

The CD-S2100 has completely symmetrical construction: the rotating loader mechanism is in the centre, the digital power supply and circuit board are on the left side, and the analogue power supply and circuit board are on the right. Completely isolating the digital unit and the analogue unit eliminates detrimental impacts of interference between the circuits, while achieving ideal weight balance. The centre frame that extends from the front to the back of the body and the front panel made of 5mm (1/4") thick aluminium increases rigidity of the entire chassis and ensures stable disk play.

Digital/analogue circuitry with integrated power supplies and screw type connections eliminate signal transmission loss

The internal design of the CD-S2100 does not separate the power supply circuit boards, which include the power transformer; the block capacitors are mounted directly on the respective digital/analogue circuit boards. Thus, an original board configuration which integrates the power supply circuits was adopted.

Eliminating cabling from the power supply circuits to each circuit board and mounting directly have the benefit of reducing connection loss, as well as achieving low impedance. Moreover, cabling from the power

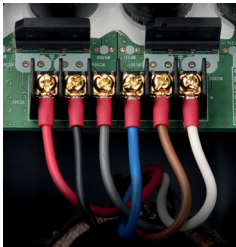

transformer utilises the same screw-type connections we've given the companion A-S2100 Integrated Amplifier. Connecting directly without soldering achieves thorough contact point loss and low impedance. Signal is transmitted to the amp without loss of any information that has been read, delivering sound reproduction filled with a sense of energy and crisp openness—the over-arching aim of the S2100 Series.

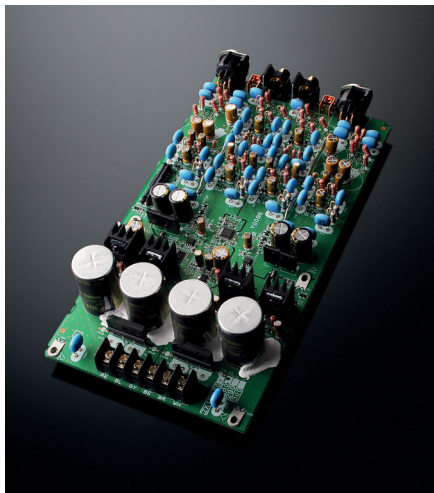

Single-stage configuration I/V conversion circuit enables direct analogue output

To thoroughly eliminate audio signal loss, the CD-S2100 adopts an innovative circuit configuration for the analogue circuit. The signal from the D/A converter is conventionally output as an analogue signal through an I/V conversion circuit configured in multiple stages. However, in the CD-S2100, the signal is output by a single-stage configuration based on a discrete design of the I/V conversion circuit. This single-stage configuration with high slew-rate sharply lowers audio signal loss compared to a multi-stage configuration circuit, and lowers NFB (Negative Feedback), eliminating any sonic suppression, resulting in a natural, spacious sound. The circuits beyond this D/A converter perform balanced transmission with a circuit

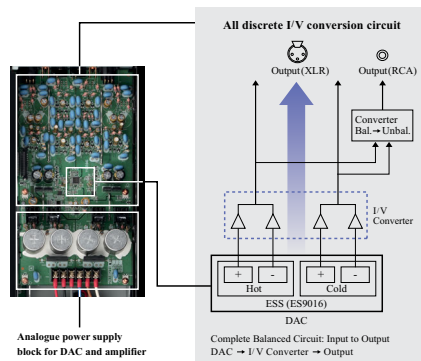

configuration marked by symmetrical plus and minus sides. Using a balanced connection with the A-S2100 Floating and Balanced Power Amplifier lets you enjoy profoundly pure sound reproduction without any impact of transmission loss.

Independent power supplies with complete separation of digital and analogue

The CD-S2100 has adopted a twin power supply transformer method, complete with separate, dedicated power supply transformers for the digital and analogue circuits.

Isolating the digital and analogue circuits starting at the transformer step eliminates sound quality deterioration caused by interference and noise between the digital and analogue units—a problem that occurs when they share the same power supply. This results in exceptionally clear, low-noise reproduction of analogue audio. Moreover, the power supply transformer for the analogue circuit is a toroidal transformer that provides stable power supply with low magnetic flux leakage, and the winding, stabilised power supply circuit is completely isolated on the left and right sides. This achieves superior separation—a particularly important point in Hi-Fi audio.





High precision CD drive for greater vibration resistance and high-precision signal reading

The CD-S2100 is equipped with the same drive mechanism as the Yamaha flagship model CD-S3000, in order to perform high-precision reading of the vast quantity of audio data recorded on a disk. And the loader mechanism is connected firmly to the chassis by installing heavy, specially specially bent 1.6mm (1/16") thick iron reinforcing anchors in front of and behind the loader mechanism, eliminating the transmission of vibration caused by disk rotation to the circuit board. In the process of assembling the CD-S2100, after the drive mechanism has been attached to the chassis, horizontal fine adjustment of each anchor is performed carefully. While this is troublesome, it shows Yamaha's commitment to providing the ultimate in precise signal reading. By eliminating even the slightest tilting of the mechanism, this achieves stabilised rotation and ultra-precise reading. Reducing the load of the servo that drives the pickup and lowering the impact of change of servo amperage on the signal, achieves clean signal read out with little impact of noise—drawing out every little nuance the artist has recorded.

High rigidity aluminium CD tray

The CD tray is made of high rigidity aluminium, reducing secondary vibrations due to resonance of the disc and the high-speed motor rotating the disc, resulting in improved audio signal-reading precision and quieter operation. In addition to the smart design and luxurious texture, we've fine-tuned the opening/closing action by

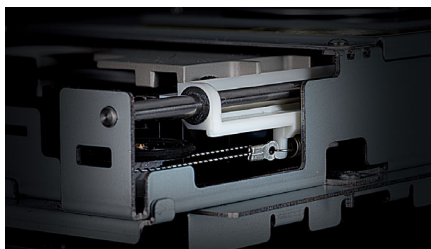

adding a specially designed meshed wire drive, achieving smoother and gentler operation. We obsessively strove to give the unit a luxurious operating feel that perfectly matches the superior sound quality.

Exceptionally high performance 32-bit D/A converter

The D/A converter for the CD-S2100 is the ES9016 from ESS Technology, Inc. We selected this after careful examination of all points—not only its high-precision processing of 32-bit audio, but also the ability to handle large amounts of audio data, strength in the low register, and high-quality definition in the high register. Since the built-in D/A converter generates its own master clock, an original Jitter Elimination function is also included, permitting D/A conversion with extremely low impact of clock jitter. Moreover, an 8-channel D/A converter is housed inside the chip, and applies double differential operation using 4-channel D/A converters on the right and left sides respectively. It delivers exceptional high performance and high-quality signal output with superior signal-to-noise ratio, since it employs an analogue signal processing circuit with balanced configuration.

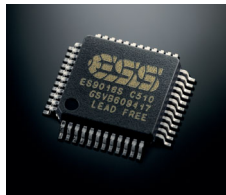

Built-in USB DAC functions, and ASIO 2.3 Yamaha Steinberg USB Driver

For optimum enjoyment of today's high-resolution audio sources, we designed the CD-S2100 with superior D/A conversion and balanced signal output, and equipped it with a built-in USB DAC function which allows direct input of digital audio (from a computer, etc.). The USB DAC employs an original IC, developed specifically for Yamaha. It has an internal master clock, and can perform low-jitter transmission. The CD-S2100 supports the ASIO 2.3 protocol to take full advantage of the sound

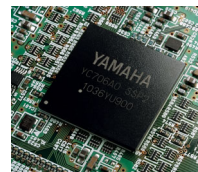

quality of the USB DAC function. The ASIO 2.3 protocol is a standard protocol for professional use digital audio or DTM, with a significant sound quality benefit: the ability to achieve lower delay and

higher throughput than with a standard OS sound driver. The driver software is the ASIO 2.3 Yamaha Steinberg USB Driver*, and allows high quality playback of digital audio data stored to computer. The unit is compatible with digital audio of up to 192kHz/24-bit resolution and supports DSD native playback.

*The software is available as a free download from the Yamaha web site.

Beautiful, sleek design and half-mirror display

Inside and out, the CD-S2100 fully demonstrates Yamaha's commitment to fine craftsmanship, and its long history as a premier maker of musical instruments. In the connections between the front panel and the side wood, masterful use of advanced processing technology beautifully integrates different materials, metal and wood. On the CD tray, the gap between the front panel and the tray is uniformly precise. The display unit is of half-mirror design, with track information beautifully displayed during CD playback, and at the same time, when the power supply is off, it harmonises beautifully with the aluminium hair-line finish of the front panel.

Remote control with simple design and superior texture

The supplied remote control is designed in the same way as the aluminium panel of the CD player itself, with a simple, easy-to-understand button layout and gorgeous metallic texture. In addition to the basic CD track selection and play controls, it can also be used to adjust the volume and switch input sources on the companion A-S2100.





Silver finish (piano finish sides)



* The sides are also available in Piano Black and Natural Birch finishes.



Black finish (piano finish sides)



* The sides are also available in Piano Black and Dark Brown finishes.

CD-S2100 Main Specifications

[AUDIO SECTION]

Media Compatibility		SA-CD, CD, CD-R/RW (MP3, WMA) , USB (Type B)
Frequency Response	CD	2 Hz-20 kHz
	SA-CD	2 Hz-50 kHz -3dB
Harmonic Distortion	CD (1 kHz)	0.002%
	SA-CD (1 kHz)	0.002%
Signal-to-Noise Ratio (IHF-A Network)	CD/SA-CD	116 dB
Dynamic Range	CD	100 dB
	SA-CD	110 dB
Output Level	CD/SA-CD (1 kHz, 0 dB)	2 ± 0.3 V

[GENERAL SECTION]

Dimensions	(W x H x D)	435 x 137 x 438 mm 17-1/8" x 5-3/8" x 17-1/4"
Weight		15.6 kg
		35.2 lbs.

